



ZTR.® 1001

OPERATORS MANUAL

IMPORTANT - READ CAREFULLY

The Dixon ZTR® Mower is both easy and fun to operate. However, any power mower must be operated properly to be safe. It is not a toy or a recreational vehicle. Before you start to use the mower, read the operator's manual carefully, and become completely familiar with the controls.

The information in this operator's manual applies to your Dixon® ZTR® Model ZTR 1001 Mower. Your Dixon dealer will gladly provide operating instructions and answer any questions.

See your dealer for warranty service, parts and repairs.



Dixon Industries, Inc.
A **BLOUNT** International, Inc. Company
P.O. Box 1569
Coffeyville, KS 67337-0945
316-251-2000

BLOUNT

INDEX

SAFETY.....	Pages	1 - 6
WARRANTY POLICY	Page	7
SPECIFICATIONS	Page	8
CONTROLS.....	Pages	9-12
OPERATION INSTRUCTIONS	Pages	13-18
CARE AND MAINTENANCE	Pages	19-26
STANDARD SERVICE PARTS LIST.....	Page	27
TROUBLESHOOTING.....	Pages	28 - 30
DIAGRAMS.....	Pages	31 -36

SAFETY

*LA WNMOWERS, IF IMPROPERLY OPERATED,
CAN CAUSE SERIOUS INJURY OR DEATH*

The most common causes of injury to the operator or bystander...



THROWN OBJECTS

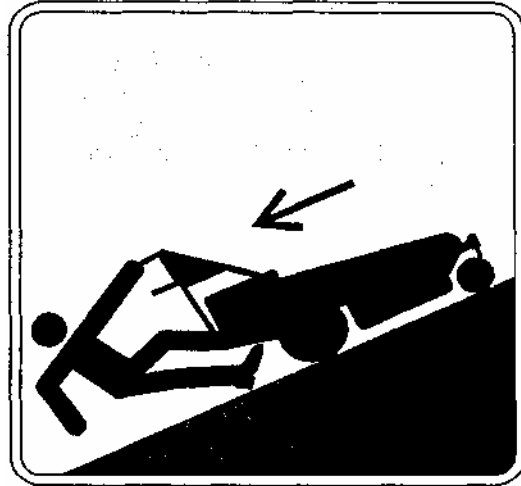

UPHILL

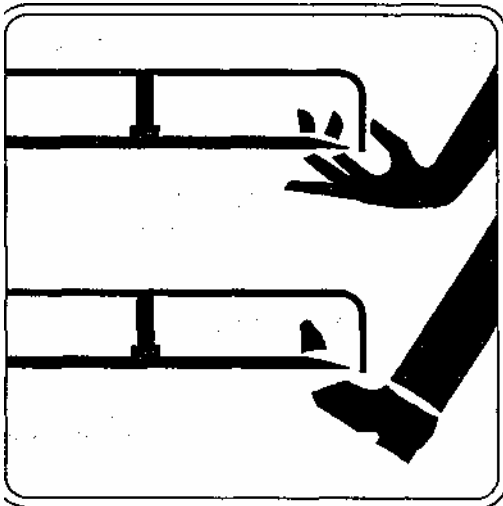

BLADE CONTACT

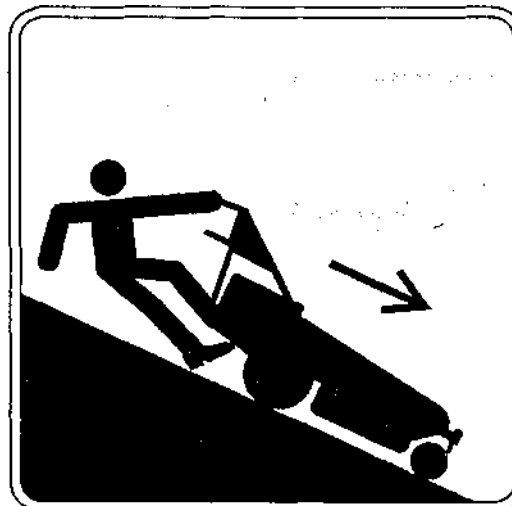

DOWNHILL

SAFETY

SAFETY SYMBOLS:



SAFETY ALERT SYMBOL -

When you see this symbol,
BE ALERT to the potential for injury.

Follow recommended safety precautions and safe operating practices.



Danger indicates an imminently hazardous situation which, if not avoided, *will* result in death or serious injury.



Warning indicates a potentially hazardous situation which, if not avoided, *could* result in death or serious injury.



Caution indicates a potentially hazardous situation which, if not avoided, may result in minor or moderate injury. It may also be used to alert against unsafe practices.

 **SAFETY**

*This cutting mower is capable of amputating hands and feet, and throwing objects.
Failure to observe the following safety instructions could result in
serious injury or death.*

GENERAL OPERATION:

- Read, understand, and follow all instructions in the manual and on the mower before starting.
- Only allow responsible adults, who are familiar with the instructions, to operate the mower.
- Clear the area of objects such as rocks, toys, wire, etc., which could be picked up and thrown by the blade.
- Be sure the area is clear of other people before mowing. Stop mower if anyone enters the area.
- Do not mow in reverse unless absolutely necessary. Always look down and behind before and while backing.
- Be aware of the mower discharge direction and do not point it at anyone. Do not operate the mower without either the entire grass catcher or the deflector in place.
- Slow down before turning.
- Never leave a running mower unattended. Always turn off blades, set parking brake, stop engine, and remove key before leaving unattended.
- Turn off blades when not mowing.
- Stop engine before removing grass catcher or unclogging chute.
- Mow only in daylight or good artificial light.
- Do not operate the mower while under the influence of alcohol or drugs.
- Watch for traffic when operating near or crossing roadways.
- Use extra care when loading or unloading the mower into a trailer or truck.

**WARNING:**

The Engine Exhaust from this product contains chemicals known to the State of California to cause cancer, birth defects or other reproductive harm.



SAFETY

SLOPE OPERATION:

Slopes are a major factor related to loss-of-control and tip-over accidents, which can result in severe injury or death.

All slopes require extra caution.

DO

Mow across the slope with your Dixon ZTR - never up or down.

Remove obstacles such as rocks, tree limbs, etc.

Watch for holes, ruts or bumps. Uneven terrain could overturn the mower. Tall grass can hide obstacles.

Use slow speed.

Use extra care with grass catchers or other attachments. These can change the stability of the mower.

Keep all movement on the slopes slow and gradual. Do not make sudden changes in speed or direction.

Avoid starting or stopping on a slope. If tires lose traction, disengage the blades and proceed slowly down the slope.

DO NOT

Do not turn on slopes unless necessary, and then, turn slowly and gradually downhill, if possible.

Do not mow near drop-offs, ditches, or embankments. The mower could suddenly turn over if a wheel is over the edge of a cliff or ditch, or if an edge caves in.

Do not mow on wet grass. Reduced traction could cause sliding. *Do not*

use grass catcher on steep slopes.

 **SAFETY****CHILDREN:**

Tragic accidents can occur if the operator is not alert to the presence of children.

Children are attracted to lawn mowers and the mowing activity.

NEVER assume children will stay where they were last seen.

Be alert to avoid accidents.

- Keep children out of the mowing area and under the watchful care of another responsible adult.
- Be alert and turn mower off if a child enters the area.
- Before and during backing, look behind and DOWN for small children.
- Never carry children. They may fall off and be seriously injured or interfere with safe mower operation.
- Never allow children to operate the mower.
- Use extra care when approaching blind corners, shrubs, trees, or other objects that may obscure vision.

 **SAFETY****SERVICE:**

- Use extra care in handling gasoline and other fuels. They are flammable and vapors are explosive.

Use only an approved container.

Never remove gas cap or add fuel with the engine running. Allow engine to cool before refueling. Do not smoke.

Never refuel the mower indoors.

Never store the mower or fuel container inside a building where there is an open flame.

- Never run a mower inside a closed area.
- Keep nuts and bolts, especially blade attachment bolts, tight and keep equipment in good condition.
- Never tamper with safety devices. Check their proper operation regularly.
- Keep mower free of grass, leaves, or other debris buildup. Clean up oil or fuel spillage. Allow mower to cool before storing.
- Stop and inspect the equipment if you strike an object. Repair, if necessary, before restarting.
- Never make adjustments or repairs with the engine running. -
- Mower blades are sharp and can cut. Wrap the blade(s) or wear gloves, and use extra caution when servicing them.
- Batteries contain sulfuric acid. To prevent burns avoid contact with skin, eyes and clothing. To prevent a fire or explosion keep sparks and open flames away from battery.

Before disconnecting the negative (-) ground cable, make sure all switches are OFF.

- Check to assure that the drive chains are properly adjusted. A loose chain may come off causing loss of control and damage to components.

DIXON LIMITED WARRANTY POLICY- MODEL ZTR 1001

This warranty policy applies to all 1001 walk behind mowers purchased on or after September 1,1996..

WARRANTY: Dixon Warranty term is for a period of one (1) year from date of purchase or 200 hours of use, whichever occurs first. Mowers used for residential homeowner applications (used only at owner's primary place of residence) are warranted for two (2) years from date of purchase or 200 hours of use, whichever occurs first. DIXON ZTR MOWERS ARE WARRANTED AGAINST DEFECTS IN MATERIALS AND WORKMANSHIP AND PROVIDES FOR REPLACEMENT OR REPAIR OF PARTS INCLUDING LABOR COSTS. THIS WARRANTY IS SUBJECT TO THE FOLLOWING CONDITIONS AND LIMITATIONS:

1. Warranty applies only to original retail purchaser of new and unused mowers and accessories.
2. All Dixon warranty must be accomplished by authorized Dixon dealers and in accordance with Dixon warranty policy and allowances. All warranty claims must be approved by Dixon Industries, Inc.
3. Battery warranty: Limited to 90 days from date of purchase.
4. Accessories Warranty (Grass Catchers, Snow Blades, Covers, etc.): Limited to 90 days from date of purchase.
5. Warranty does not apply to damage in transit or incidents of misuse, negligence, accidents, or alteration. The use of parts or components other than those supplied by Dixon Industries, Inc. VOIDS ALL WARRANTY.
6. The following items are not covered by this warranty policy:
 - (a) Pick up and delivery charges for transportation of mower to and from an Authorized Dixon Dealer's place of business.
 - (b) Routine maintenance or adjustments.
 - (c) Belts / chains / sprockets / cutting blades.
 - (d) Engines -- All engines used on Dixon ZTR mowers are warranted by each individual engine manufacturer.
 - (e) Any costs or expense of providing substitute equipment while repair work is being performed on a warranted mower.
7. There is no other express warranty. Implied warranties, including those of merchantability and fitness for a particular purpose, are limited to the same duration of the express warranty, and to the extent permitted by law any and all implied warranties are excluded. Liabilities for consequential damages under any and all warranties are excluded.

WARRANTY VALIDATION: At the time of sale, selling dealer must review each portion of this warranty document, complete the information section below, secure customer's signature and send copy to Dixon Industries, Inc.

DATE OF PURCHASE _____ Model _____ S/N ^{DM#} _____

(Owner's Name)

(Dealership)

(Address)

(Address)

(Owner's Signature)

(Dealer's Signature)

SEE DEALER FOR DETAILS

SPECIFICATIONS

Model ZTR 1001

CHASSIS:	The monocoque design chassis of the Model ZTR 1001 incorporates CMC laser and CNC brake processes to form the twin 12 gauge side frames and 7 gauge transmission and engine base plate.		
BODY:	The front body cover is made of rotational molded polyethylene. Front body contains access panel for battery service.		
MOWER DECKS:	Cut height approximately 1" to 4" via 7 position lift handle. Each deck is stamped steel construction:		
	36"-11 gauge 2 blades 36" cut width	42"-13 gauge 3 blades 42" cut width	50"-10 gauge 3 blades 50" cut width
BLADE DRIVE:	Electric clutch.		
TRANSMISSION:	Each rear wheel is independently driven by chain and sprockets through a friction mechanical drive.		
ENGINE:	15HP Kohler Command, 4-Cycle, Single Cylinder, Overhead Valve, Air-Cooled, Pressure Lubricated, With Oil Filter, Vertical Shaft, Aluminum Head and Block with Cast Iron Cylinder Liner.		
STARTING SYSTEM:	Electric by key switch operation with safety interlocks on parking brake and blade drive.		
TIRES:	Front	9 X 350 X 4 ribbed tread.	
	Rear	16X6.50 X 8 Multi Trac Tread.	
CAPACITIES:	Fuel:	2.7 gallons total	
	Engine:	2 quarts oil.	
DIMENSIONS:	Width	Overall width with deflector retracted:	
		36" deck: 39"	42" deck: 46 1/2" 50" deck: 52 1/2"
	Length	77" overall.	
	Weight	36" deck: 494 lbs.	42" deck: 510 lbs. 50" deck: 532 lbs.
NOTE:	Additional information provided in service instructions under the individual component.		

SPECIFICATIONS SUBJECT TO CHANGE WITHOUT NOTICE

CONTROLS

The Dixon ZTR has a unique transaxle that requires only two drive levers to control braking, turning, speed, and direction.

On initial operation, set throttle speed on slow and operate with mower blade "OFF". To avoid "over-controlling" the mower, use a light touch on the drive levers. Slight movements are all that is necessary.

All controls are described from operators position:

PARKING BRAKE:

The parking brake used on the Model ZTR 1001 is designed to hold the mower from moving and is *not* intended for use in stopping the mower while it is in motion.

NOTE: Engine cannot be started unless the brake is applied.

Do not leave engine running for extended periods of time without the parking brake engaged.

TO SET PARKING BRAKE:

The hand operated parking brake bail and associated catch stop is located mid-point between the control levers.



CAUTION BRAKE HANDLE IS SPRING TENSIONED

To engage brake: Grasp brake bail with one hand while releasing catch stop by pushing downward with the other hand.

To release brake:

BRAKE BAIL WILL SWING UP AND FORWARD

Move brake bail downward until catch stop latch is fully engaged.

NOTE: Parking brake must be in RELEASED position in order to activate electric blade clutch for mowing.

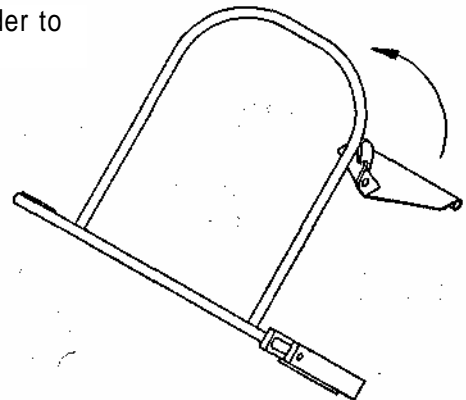
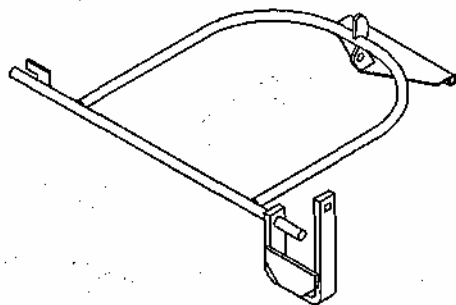

CONTROLS

TRANSMISSION DRIVE SYSTEM:

Allows the mower to turn on its own axis (zero turning radius). Each lever controls one side of the mower.

NOTE: The pressure required to operate the mower is very light.

A minimum of 1/2 hour should be spent simply driving the mower without the blade drive engaged.

TO GO FORWARD:

From neutral position, gently push both drive control levers downward or forward.

To increase speed, move levers farther downward or forward.

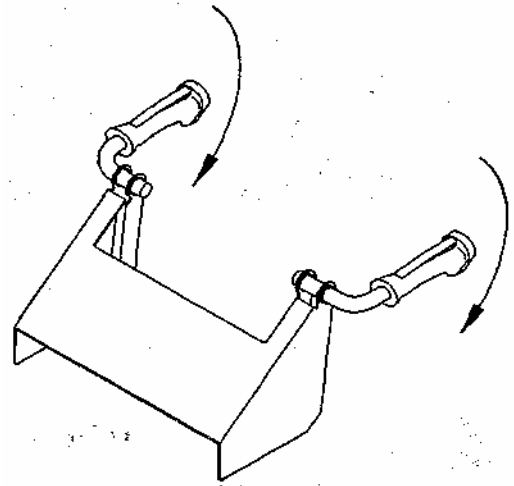

FORWARD

TO GO BACKWARD:

From neutral position, gently pull both drive control levers toward you.

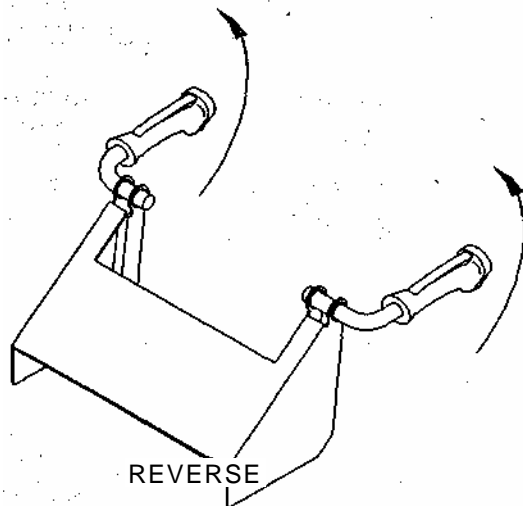

REVERSE

CONTROLS

TURNING:

Turning is controlled by moving one drive control lever slightly up or down, forward or rearward of the other.

To turn left, move left control lever up while pushing downward on the right control lever.

To turn right, move right control lever up while pushing downward on the left control lever.

To turn on mower's own axis 'Zero Turning Radius' stop and move one lever to reverse or up position and the other to forward or downward position. >,- •.

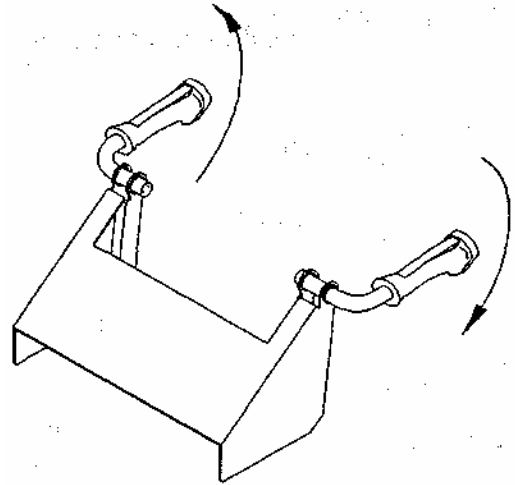

90° RIGHT TURN

BRAKING:

To brake mower, move both levers in direction opposite of travel, release levers to move neutral setting. Set parking brake. Park on level surfaces only.

TWIN FUNCTION THROTTLE CONTROL LEVER:

Located on control panel to operators right.

Throttle control for engine speed. Choking for engine starting.

Throttle control should be set to the MAXIMUM or wide open setting to insure adequate cooling of the engine and to maintain mower deck blade speed while mowing.

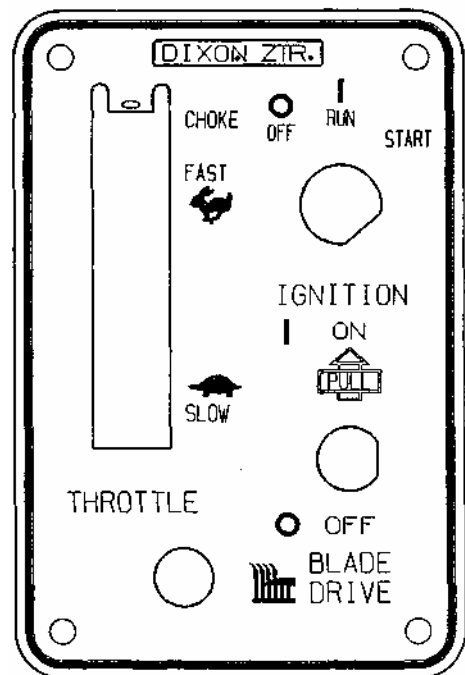

CONTROLS

BLADE DRIVE:

Located on control panel above and to operators right.

To engage the mower blades, release parking brake by moving brake bail downward until catch stop latch is fully engaged.

Grasp left control handle grip with enough pressure to depress built in safety switch. If constant pressure is not maintained on either handle grip when blade drive is engaged, engine will stop.

Using right hand, lift blade drive switch up and push forward.

To disengage blades, pull switch backward. Switch is clearly marked "ON and OFF".

MOWER DECK CUT HEIGHT LIFT LEVER:

Located to the right of operator.

Controls the cutting height.

Seven positions of adjustment.

Move lever in and forward to lower.

Move lever in and back to raise.

NOTE: Always use high position for transport.

CIRCUIT BREAKER:

Located on control panel to operator's right.

Protection of the electrical system is by (1) 15 amp circuit breaker.

If circuit breaker trips, push button to reset.

If this condition repeats, consult dealer for inspection and repair.



OPERATION INSTRUCTIONS

The safe and successful operation of the Model ZTR 1001 will depend upon the operator having the correct knowledge of all controls used on the mower and making good judgements about the terrain to be mowed.

NEVER allow anyone to operate the mower without complete knowledge of all controls and their functions.

During initial operation, set throttle at slow speed. Sound judgement by the owner will prevent accidents.

BEFORE OPERATING MOWER:

- 1. Read engine manufacturer's operating and maintenance instructions.**
- 2. Discuss proper maintenance with your dealer.**
- 3. Read and observe all safety instructions on your mower and in the manual.**
- 4. Check engine oil.**
- 5. Check gas cap to be sure it is in place.**
- 6. Be sure parking brake is on.**
- 7. Mower blade drive is off.**
- 8. Know how to stop engine. (Turn key to off position)**

OPERATION INSTRUCTIONS



TESTING OF SAFETY INTERLOCK SYSTEMS:

PARKING BRAKE SWITCH TEST: With parking brake bail locked moved downward and locked into the catch stop, engine should not turn over or attempt to start when the key switch is moved to the start position.

BLADE DRIVE SWITCH TEST:

NOTE: Each drive control lever is fitted with an OPERATOR PRESENCE switch.

- a. With electric blade drive switch turned ON, engine should not turn over or attempt to start when key switch is moved to the start position.
- b. In a SAFE AREA away from bystanders, start the engine, place throttle setting at maximum or full. Engage blade drive clutch switch. Remove hand from either control lever. Engine should stop.

NOTE: Both LEFT and RIGHT control levers have OPERATOR PRESENCE switches which require constant pressure to allow the blade drive clutch switch to function.

- c. If any Safety Check fails, do not operate the mower until the system has been checked and repaired by an Authorized Dixon ZTR Dealer.



OPERATION INSTRUCTIONS

STARTING INSTRUCTIONS:

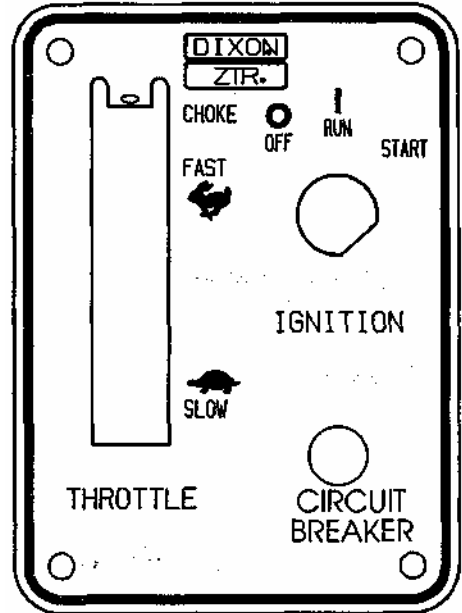
1. Grasp parking brake bail handle with one hand while releasing catch mechanism located mid-point between the control handles.
2. Move throttle control to choke position if engine is cold, full throttle if warm.
3. Insert ignition key and turn to start position. When engine starts, release ignition key. Key will return to run position.
4. Move throttle from choke to desired speed position.



NOTE: While mowing, "blade(s) engaged", throttle control should be set to the MAXIMUM or wide open setting to insure adequate cooling of the engine and to maintain mower deck blade speed.

CONTROL HANDLE OPERATION	! CAUTION
REVERSE 	<ul style="list-style-type: none"> ○ Engine will not start unless the brake bail is in the upward position and blade drive is turned off. ○ Unit will not move until brake bail is lowered and secured by brake bail latch assembly. ○ For braking, move control handles opposite direction of travel or depress brake bail release to automatically engage parking brake.
NEUTRAL 	
FORWARD	
	<p>DIXON INDUSTRIES, INC. A BLOUNT COMPANY BOX 1569 COFFEYVILLE, KANSAS 67337-0494</p>

Engine cannot be restarted when blade is engaged or the parking blade is off.

Safety switches stop engine when operator leaves seat while mower blade is engaged.

Always turn engine off when leaving mower.

DO NOT rely on safety switches.

OPERATION INSTRUCTIONS

MOWING WITH A MULCHING ATTACHMENT:

Mulching or recycling the grass clippings requires a totally different mowing approach than would be normal when side discharging or bagging the grass. There may be instances or conditions where it is not possible to hide all of the recycled or mulched clippings.

In order to achieve the best results, please read and follow the mulching tips listed below:

1. Set the engine speed control to the wide open or full setting.
2. Place the mower deck cut height selector in either the top or second notch. Never cut more than 3/4" to 1" off the grass at any one time. Attempting to cut more grass will result in the deck plugging and cause the engine to stall.
3. It may be necessary to cut the lawn twice to achieve acceptable mulching performance especially on first cuttings or if the lawn is heavily fertilized.
4. *Do Not Attempt To Cut Grass When It Is Wet.* Mulching performance will be very poor under wet grass conditions.
5. *Maintain Sharp Blade(s) Throughout The Cutting Season.* This is very important. Optimal mulching performance cannot be obtained with a dull or nicked up blade.
6. *Keep The Underside Of The Mower Deck Clean.* Remove all grass and dirt buildup from the underside of the pan, the baffles and deflectors after each use.
7. Alternate mower direction. This will evenly disperse the mulched grass clippings over the lawn for even fertilization.

If the mulching quality of the mower does not seem to be satisfactory, try one or more of the following tips:

1. Raise the height-of-cut setting on your mower.
2. it may be necessary to cut your grass more frequently.
3. Operate the mower at a slower ground speed.
4. Overlap cutting swaths instead of cutting a full swath with each pass.
5. Mow across the marginal areas a second time.
6. CUT HIGH - MOW OFTEN!

OPERATION INSTRUCTIONS

MOWING WITH A GRASS CATCHER ATTACHMENT:

In order to achieve optimum performance when mowing with a grass catching attachment, please read and follow the tips listed below.

1. Set engine speed control to the wide open or full setting.
2. *Do Not Attempt To Cut Grass When It Is Wet.* Wet grass will clog both the underside of the deck and the attachment chutes. Empty bags often to prevent plugging.
3. If the grass is tall, place the mower deck cut height selector in the top or second notch. "Initially" overlap cutting swaths instead of a full swath with each pass.
4. *Keep The Underside Of The Mower Deck Clean.* Frequent removal of dried grass and dirt will greatly assist in bagging of the clippings.
5. Use only the correct blade(s). Some grass catching attachments require a "high-lift" blade. See your dealer for advice on the type of blade(s) needed for your mower.
6. *Maintain Sharp Blade(s) Throughout The Cutting Season.*
7. Operate the mower at a slower ground speed than when mowing without a grass catching attachment.



CAUTION

- Watch for low hanging branches or other obstacles which might hit the catcher top while turning or backing the mower.
- Use care when backing to avoid pushing the grass bags into the frame or "hot" exhaust muffler of the engine.
- Disengage blade and stop engine prior to clearing grass from either the discharge chute or grass catcher components.
- Keep all attachment bolts tight.
- *Do Not* operate the mower with the grass catching attachment partially removed.
- Important:
 - * Do not leave clippings in the bags while the mower is stored.
 - Damp grass clippings are a fire hazard if left in the bags.

OPERATION INSTRUCTIONS

SIDE DISCHARGE OF THE CLIPPINGS:

In order to achieve optimum performance when side discharging the grass clippings, please read and follow the tips listed below.

Additional information can be found in the troubleshooting guide.



CAUTION Be sure that deflector is properly installed on the discharge chute.

1. Set engine speed control to the wide open or full setting.
2. *Do Not Attempt To Cut Grass When It Is Wet.* Wet grass will clog the underside of the deck and discharge area.
3. If the grass is tall, place the mower deck cut height lever in the top or second notch. "Initially" overlap cutting swaths instead of a full swath with each pass. Some applications may require a second cutting.
4. *Keep The Underside Of The Mower Deck Clean.* Frequent removal of dried grass and dirt will allow the clippings to discharge correctly.
5. *Maintain Sharp Blade(s) Throughout The Cutting Season.*

GRASS HEIGHT SUGGESTIONS:

Correct mowing height can reduce weeds and disease by 50 to 80%

The following grass cut heights are based on adequate moisture conditions and normal thatch buildup in a healthy lawn. Some locations and applications may require slightly different cut heights. If in doubt, consult your local lawn professional for assistance.

Grass Types:

Best Cut Heights:

Zoysia	2" - 2 1/2"
Blue Grass	1 1/2" - 3"
Fescue Blends	1 1/2" - 3"
St. Augustine (Mid South)	1 1/2" - 2"
St. Augustine (Deep South)	3" - 4"
Tifton Bermuda	1 1/2"
Centipede	1 1/2" - 2"
Common Bermuda	1 1/2" - 2"
Bahia/Argentina/Pensacola-	2"

CARE AND MAINTENANCE - MODEL ZTR 1001

This portion of the Model ZTR 1001 owners manual deals with normal service items which can be performed by the owner. Please remember that if you are in doubt as to the correct service procedures to be followed, these and other service situations can be handled by a Dixon ZTR dealer who is familiar with the service of your mower.

MAINTENANCE SCHEDULE:

To insure a long and trouble free service life on all the components used on the Model ZTR 1001, a regular and thorough maintenance schedule should be followed. The following items should be checked after the first (10) hours of operation and on a weekly basis, or each (40) hours of use:

1. Drive chain.
2. Drive system, belts and controls.
3. Mower deck belts.
4. Tire pressures.
5. Tightness of all nuts and bolts.
6. Battery fluid level.
7. Engine oil.



CAUTION

Before performing any maintenance, shut off engine, allow to cool.

ENGINE: For engine operating and maintenance information, refer to the engine operating and maintenance instructions furnished by the engine manufacturer, supplied with each mower.

BATTERY: Check the fluid in the battery at frequent intervals.
Keep fluid level above the plates in each cell, using distilled water.

OFF-SEASON BATTERY STORAGE:

Identify each cable so cables can be reconnected to correct terminals.

Disconnect cables from terminals.

ALWAYS disconnect ground cable first and reconnect last.

Charge battery.

DO NOT remove battery from mower.

Clean top of battery and terminals with baking soda and water.

CARE AND MAINTENANCE - MODEL ZTR 1001

CUTTER BLADE MAINTENANCE:

NOTE: Observe proper blade position prior to removal.

1. Safely raise front of mower.
2. Hold or block blade from turning.

CAUTION  **Wear heavy, thick gloves when holding onto cutter blade, avoid the sharp edge of the blade.**

NOTE: Be sure blade is centered on pilot before tightening bolt to 60 ft. lbs. torque.

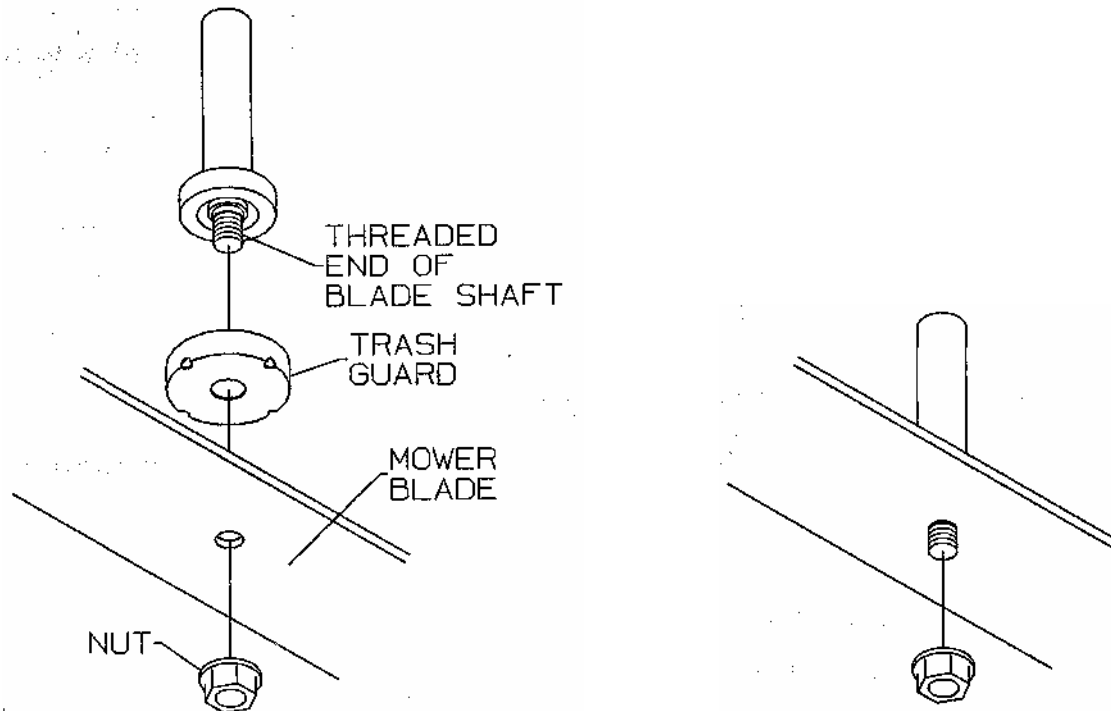

CARE AND MAINTENANCE - MODEL ZTR 1001

BELT TENSION 42" & 50" DECKS:

ENGINE TO MOWER DECK BELT:

No adjustment required.

Correct belt tension is maintained through a fixed engine location and a spring loaded idler system.

A pulsing movement of the belt idler will be observed both during engagement of the electric blade clutch and actual operation of the mower deck.

NOTE: Engagement of the electric blade clutch switch may produce a sharp high pitched chirp or squeal as the belt tension loading is absorbed by the idler system. This is normal and not a sign of failure.

MOWER DECK SERPENTINE BELT:

Refer to illustration for adjustment procedure.

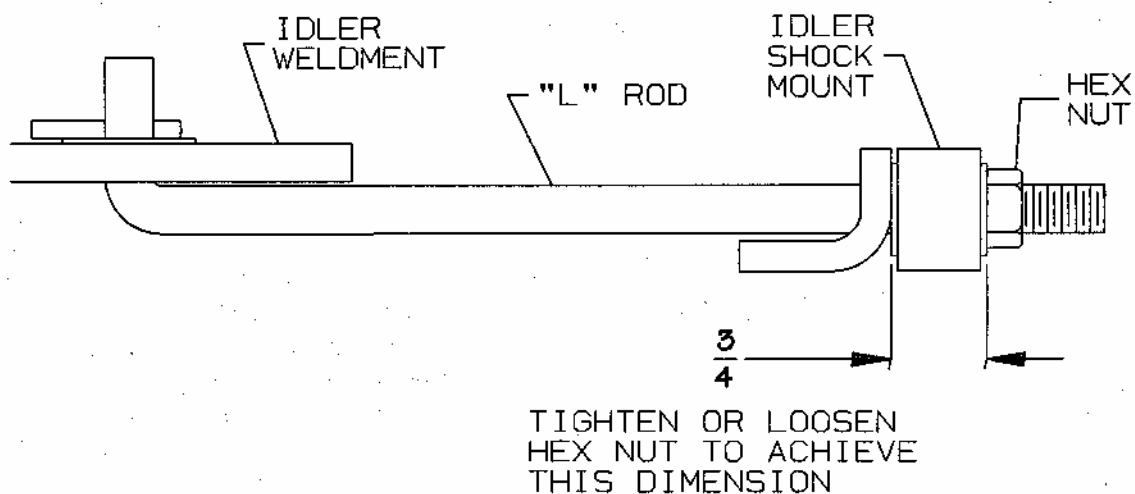

CARE AND MAINTENANCE - MODEL ZTR 1001

BELT TENSION 36" DECK:

ENGINE TO MOWER DECK BELT:

Adjust idler shock mount per diagram.

When fitted, the 36" mower deck belt tension is maintained through an adjustable idler and shock mount. To adjust belt tension, tighten hex nut until rubber shock mount is compressed to the dimension shown in the illustration below.

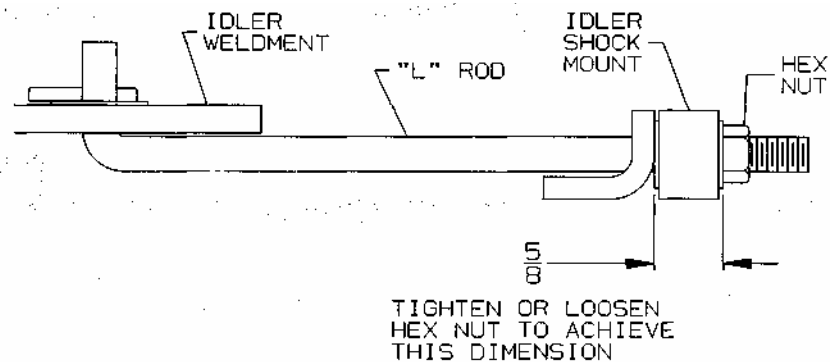

LUBRICATION:

- CHASSIS:** Number of grease zerks used: (4)
- LOCATIONS:** (1) each front wheel caster and each front wheel hub
- SERVICE INTERVALS:** Every 50 hours of operation
- RECOMMENDED GREASE:** Name brand wheel bearing or multi-purpose grease

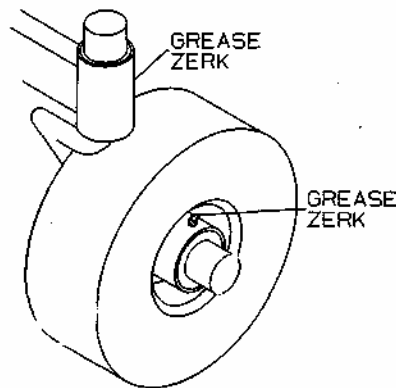

Lubricate each front wheel to allow even distribution of grease within the wheel, rotate or spin each front wheel after (3) pumps of the grease gun. Repeat process until the appearance of grease is noted completely around each caster axle.

CARE AND MAINTENANCE - MODEL ZTR 1001

DECK REMOVAL:

1. Place cut height lever in lowest cut position.
2. Loosen belt keepers on each side of engine pulley.
3. Remove deck drive belt from engine pulley.
4. Using a slight upward twisting motion, remove link from engagement handle.
5. Turn handle fully to the left until handle clears stop on mower deck pan. Lift and remove handle through hole in lower body.
6. Remove pin and washer from one end of deck support shaft. Note location of remaining shim washers used between chassis and mower deck pan arms. Slide shaft from chassis and mower deck. (Refer to illustration below)
7. Remove pin and washer from each deck adjustment rod. Carefully push each link toward the inside of the mower chassis. At this point, deck will drop down.
8. Carefully raise and support front of chassis. Slide mower deck to either side for removal. (Reverse procedure to reinstall deck assembly)

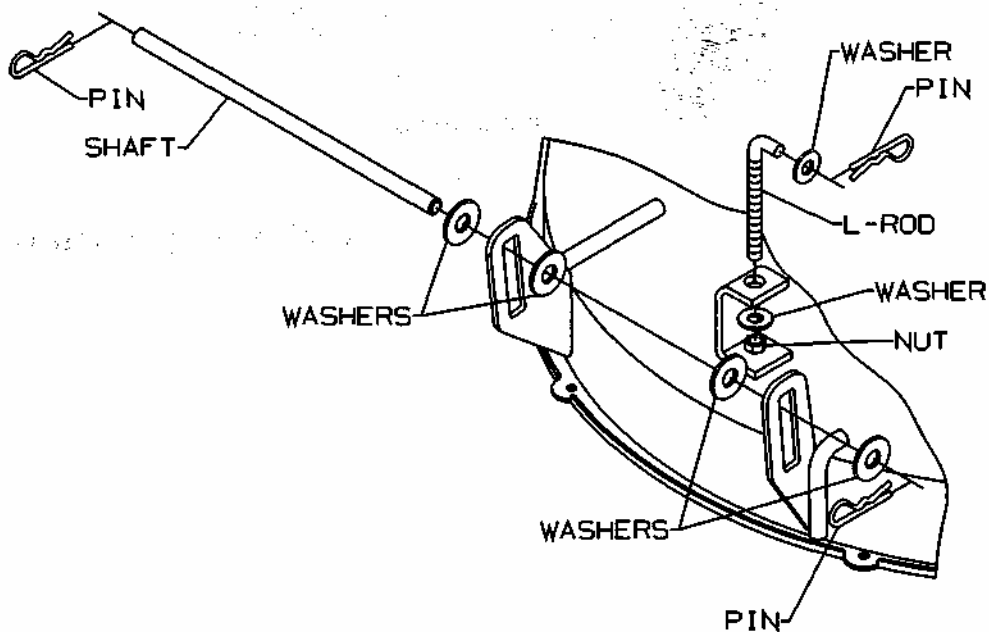

CARE AND MAINTENANCE - MODEL ZTR 1001

⚠ CAUTION HOT oil may cause burns. Allow engine to cool before draining oil.

CHANGING THE ENGINE OIL:

1. The "snap lock" oil drain valve is located on the left side of the engine crankcase.
2. Place a suitable container under the drain valve. The fitting of a short piece of hose to the valve will help direct the oil.
3. Push the valve body in and *twist* to clear the detent notch.
4. *Pulling* the valve body outward will start the flow of oil.

NOTE: Refer to engine manufacturers recommendations for frequency of oil changes.

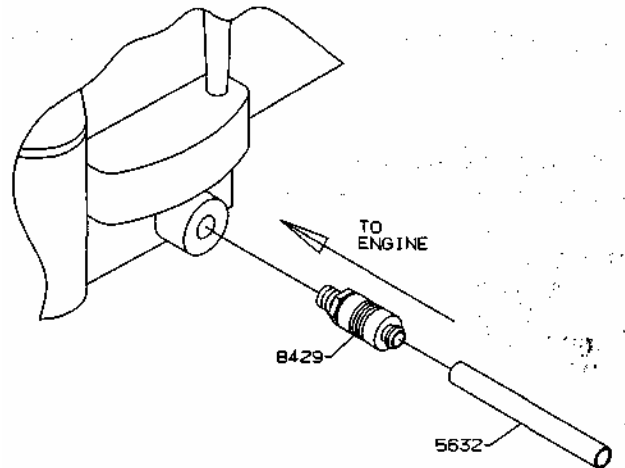

OIL FILL:

1. Push the valve body in and twist into the detent notch.
2. Clean any spilled oil from engine and chassis.
3. Refill engine with type, and quantity of oil recommended by the engine manufacturer in engine literature.

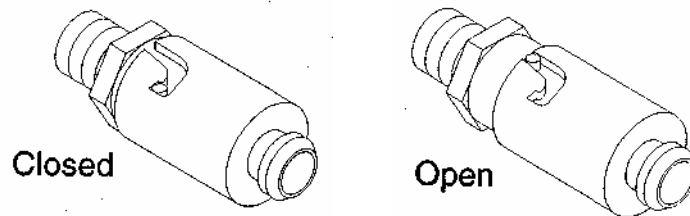

**PLEASE DISPOSE OF USED OILS AT PROPER COLLECTION CENTERS
PROTECT YOUR ENVIRONMENT**

CARE AND MAINTENANCE - MODEL ZTR 1001

DRIVE SYSTEM ADJUSTMENTS:

Due to both the complex nature of the transmission and the number of special tools required for service, adjustments should be entrusted to your dealer.

There are a number of simple owner service items which greatly influence the performance of the drive system.

1. Front and rear tires must be inflated to proper specifications.
2. Rear drive chain tension.
3. Tightness of all controls and linkages pertaining to the drive levers.
4. Lubrication of both primary and final drive chains. The use of a high quality chain lubricant is highly recommended.

REAR CHAIN ADJUSTMENT:

Adjustment of the rear drive chains of the Model 1001 is accomplished in the manner shown in the illustration below.

Proper tension and lubrication of the rear drive chains with a quality chain lubricant is essential for safe operation of this model.

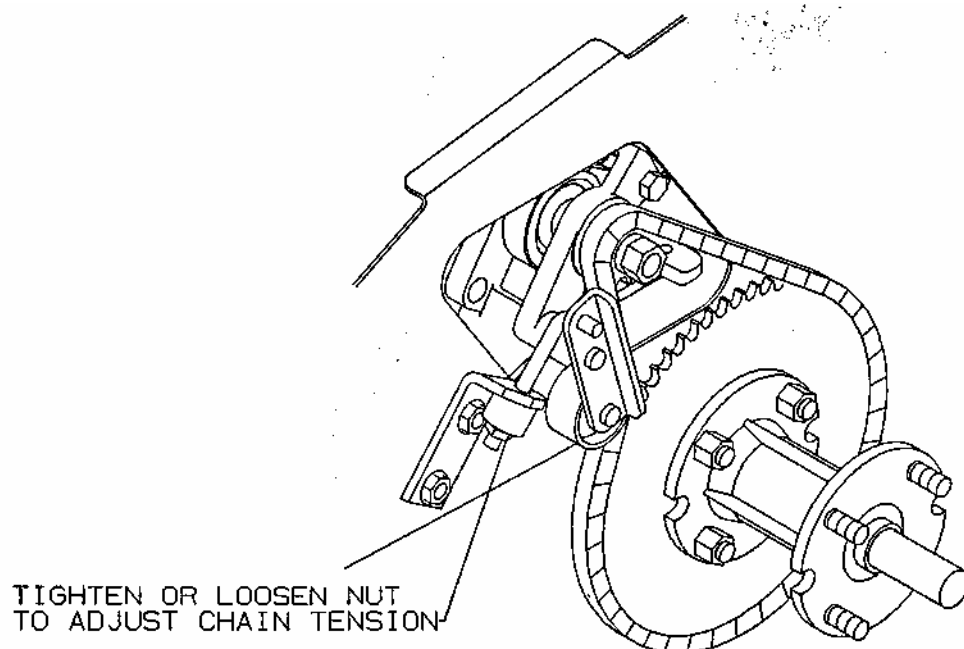

CARE AND MAINTENANCE - MODEL ZTR 1001

WHEELS AND TIRES: Correct tire pressure is important for correct operation of mower.

Front Tires 9 X 350 X 4 Air Pressure 16-21 lbs.

Rear Tires 16 X 650 X 8 Air Pressure 8-14 lbs.

NOTE: Check lug nuts periodically for tightness.

ELECTRICAL SYSTEMS: Keep all connections clean and tight.

CLEANING THE MOWER: Wash mower periodically. Clean
above and below deck.

NOTE: Allow mower to cool before washing. If bearings are hot, they will draw moisture inside as they dry and cause corrosion.

SERIAL NUMBERS: The serial number is located on frame at rear of engine, it will begin with DM.

WARRANTY: Refer to Warranty Registration Form (P/N 8871).

PARTS/SERVICE: See your Dixon dealer for replacement parts, warranty or service.

*PLEASE HELP PROTECT THE ENVIRONMENT BY AVOIDING ALL
CHEMICALS WHICH MAY DAMAGE OR CAUSE HARM TO PLANTS AND
ANIMALS IN YOUR AREA*

STANDARD SERVICE PARTS LIST

MODEL ZTR 1001:

BLADES:	36"	42"	50"
Lo-Lift:	P/N 1324	P/N 6236	P/N 9443
Hi-Lift:	P/N 1351 RH P/N 1352LH	P/N 8688	p/N 9444
BELTS:			
Engine to Mower Deck:	P/N 7835	P/N 7725	P/N 7725
Engine to Transmission:	P/N 2497	P/N 2497	P/N 2497
Serpentine Belt:		P/N 61 09	P/N 1300

KOHLER AIR FILTER PART NUMBERS:

Please refer to Kohler Engine Operators Manual for correct service intervals for engine oil changes and air filter maintenance.

Protect your engine investment, use only original equipment filters. The correct Kohler part numbers are shown in the illustration below:

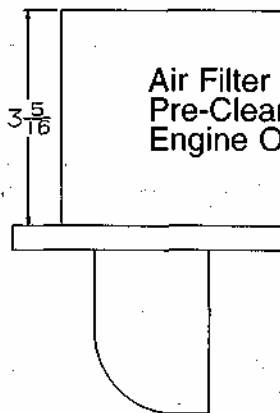

Air Filter Cartridge: P/N 12 08 310
Pre-Cleaner: P/N 12 08 312
Engine Oil Filter: P/N 52 050 02

TROUBLESHOOTING

MOWER CUT QUALITY:

There are many variables that can effect the cut quality of any mower. Type and conditions of grass, cut height setting, engine RPM and ground speed are some of the variables that interact creating differences in cut quality. Examination of one or more of the above will generally produce a quality cut.

The Troubleshooting Chart suggests practices and adjustments that may be helpful in improving cut quality. Your Dixon ZTR dealer is also available to provide assistance to you.

SITUATION	CAUSES	REMEDY
Poor cut quality	Engine RPM too low	Increase engine RPM to maximum
Poor cut quality	Ground speed	Reduce mowing speed
Poor cut quality	Grass buildup under mower deck	Clean out underside of mower deck
Poor cut quality	Dull or bent blade	Sharpen or replace as required
Poor cut quality	Incorrect engine to mower deck belt	Use ONLY original equipment belts
Poor cut quality	Uneven tire pressures	Check and adjust as required per operators manual
Poor cut quality	Improper blades	Replace with original equipment blade designed for the size of mower deck fitted.
Poor cut quality	Un-level mower deck	Consult your dealer

TROUBLESHOOTING

DRIVE SYSTEM:

SITUATION	CAUSES	REMEDY
Mower pulls to one side or the other	Drive adjustment	Consult your dealer for repair
Poor driving performance	Operation of mower	Review operators section of owners manual

TROUBLESHOOTING

ELECTRICAL SYSTEM:

SITUATION	CAUSES	REMEDY
Starter will not turn engine over	Circuit breaker engaged	Push button to reset Consult your dealer for repair
Starter will not turn engine over	Dead battery	Charge battery
Battery discharge	Poor connections on battery Battery water low Wrong battery installed in mower	Tighten or replace as required
Battery discharge	Engine electrical system not functioning correctly	Have electrical system checked by your dealer
Battery discharge	Engine being operated at too low an RPM	Increase engine RPM Contact your dealer for information

NOTE: Electrical system failures are generally simple in nature, always check the obvious first and then move onto the more complicated parts used. Poor battery service, loose connections, corrosion, frayed or broken wiring, are more likely than component failure.

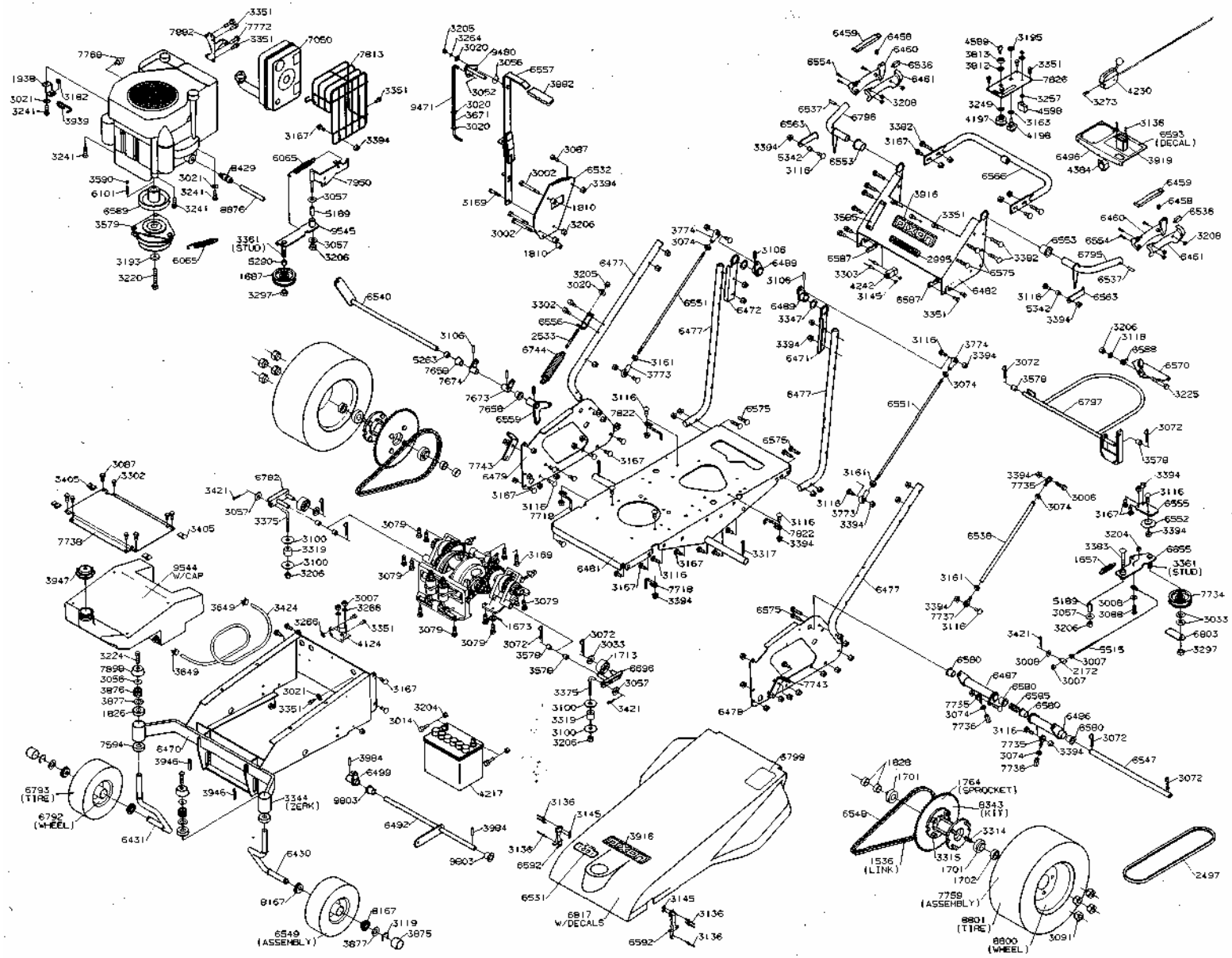

DIXON® ZTR®

1997 1001 TRANSAXLE

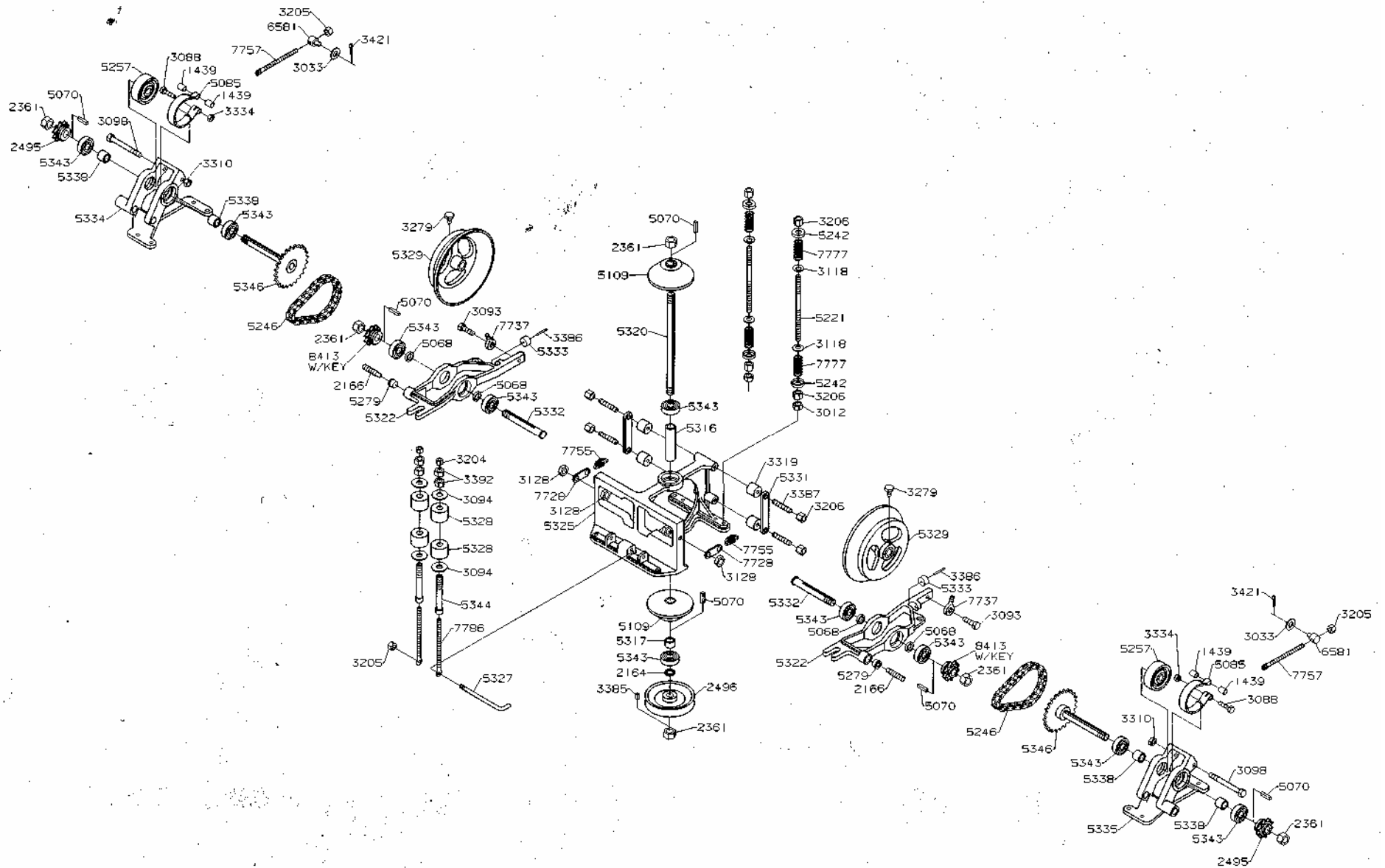

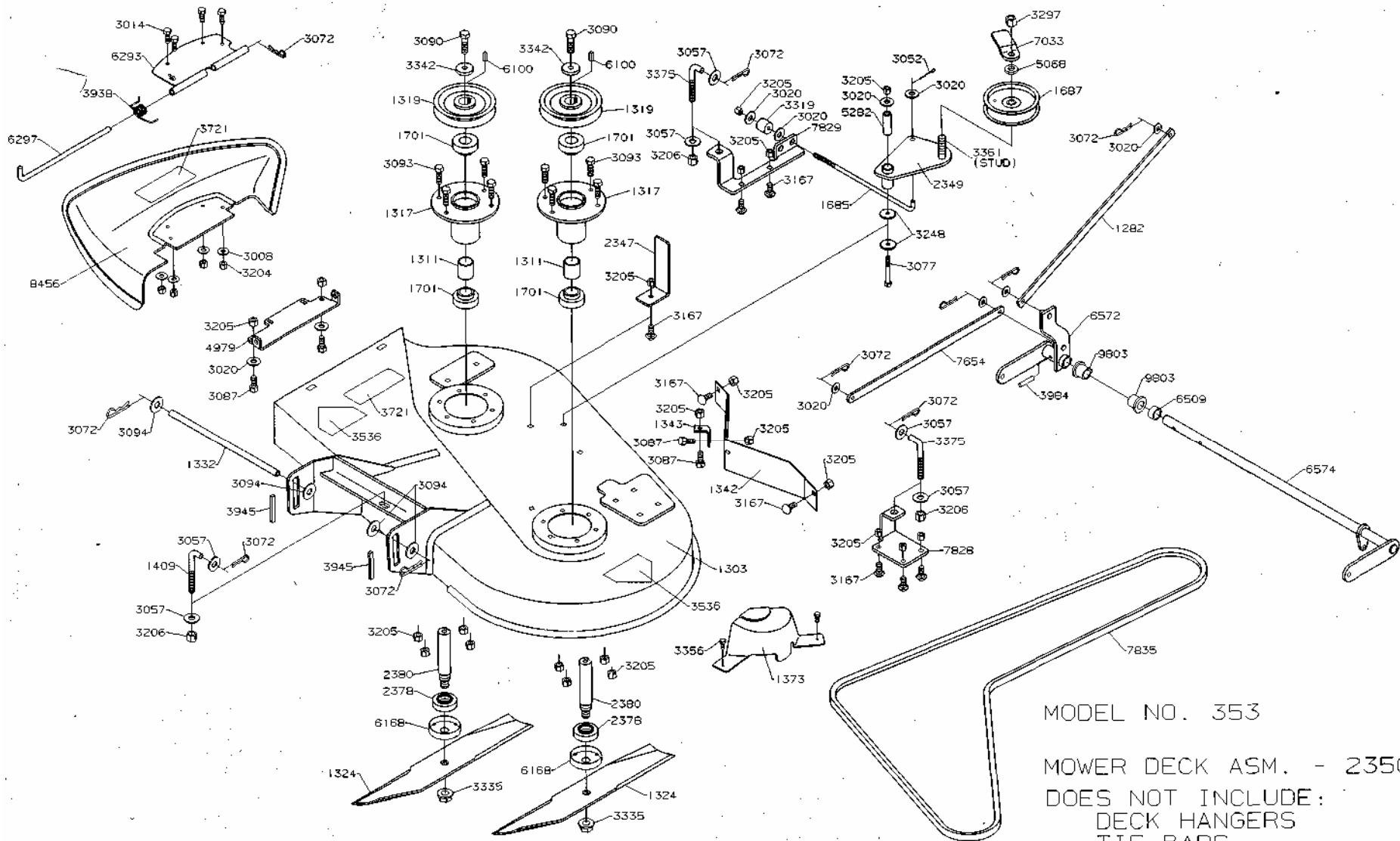

MODEL NO. 353

MOWER DECK ASM. - 2350
 DOES NOT INCLUDE:
 DECK HANGERS
 TIE BARS
 LIFT SHAFT

DIXON® ZTR®

1997 1001 MOWER DECK (42")

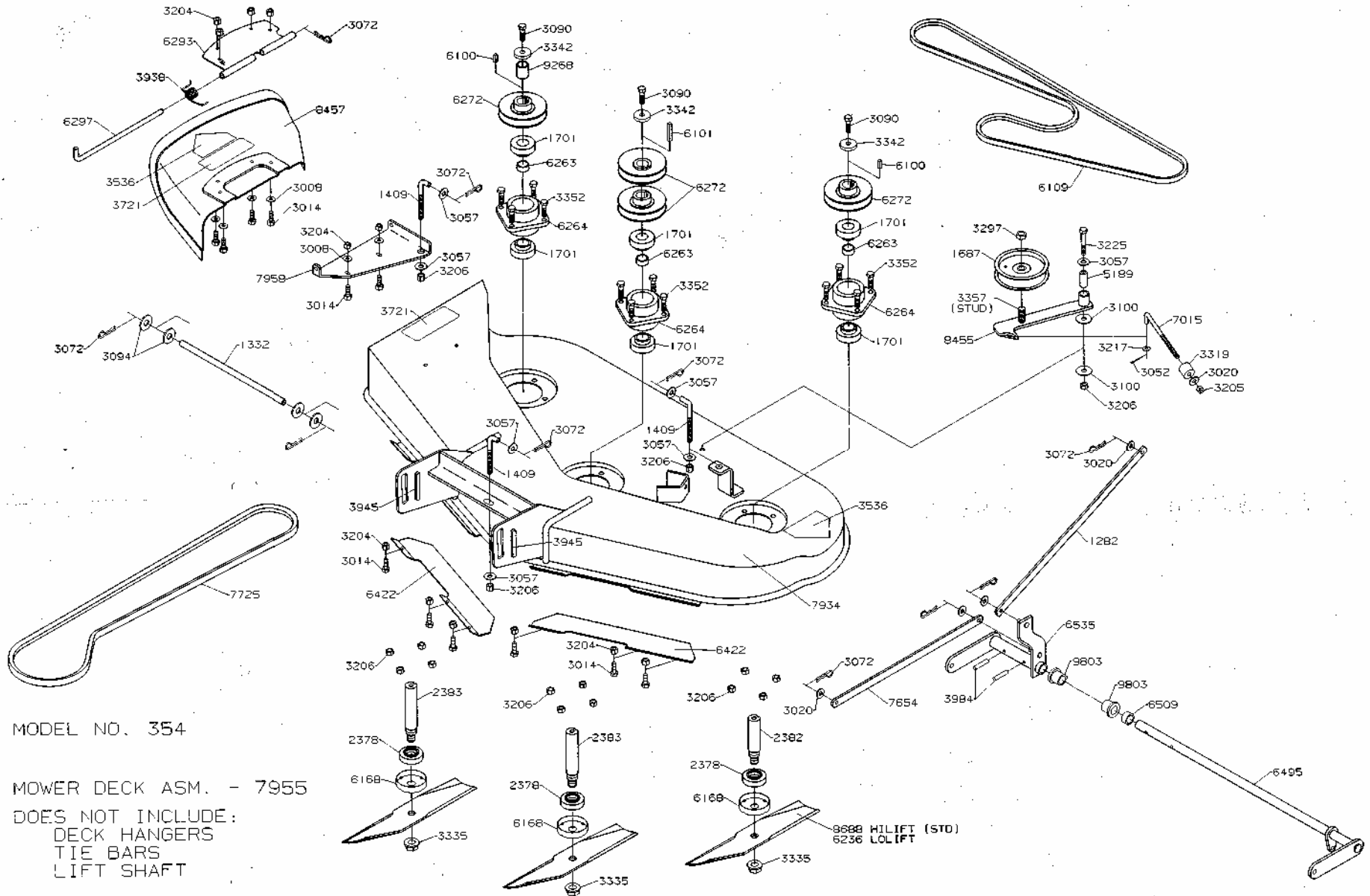

MODEL NO. 354

MOWER DECK ASM. - 7955

DOES NOT INCLUDE:
DECK HANGERS
TIE BARS
LIFT SHAFT

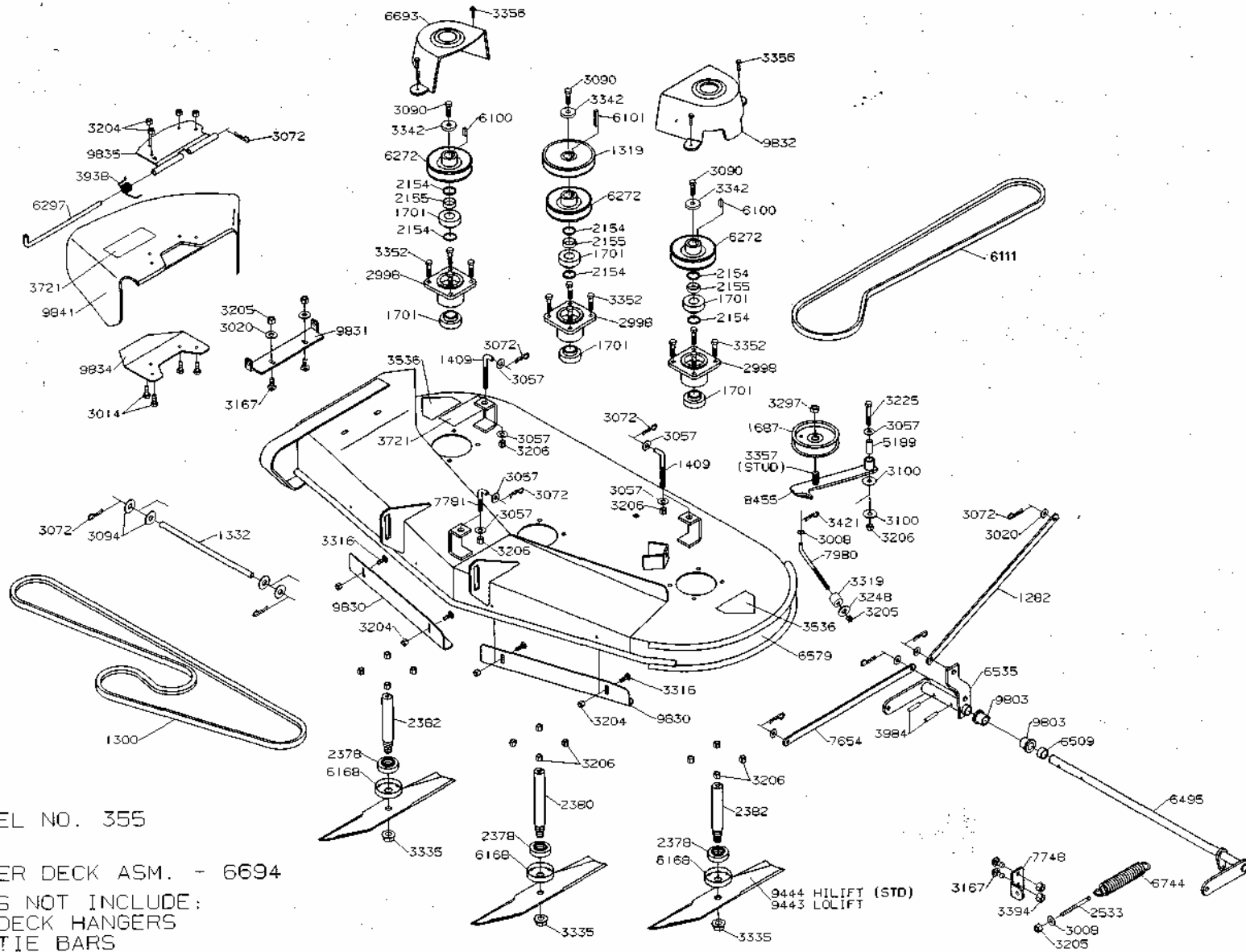

MODEL NO. 355

MOWER DECK ASM. - 6694

DOES NOT INCLUDE:
 DECK HANGERS
 TIE BARS
 LIFT SHAFT

DIXON® ZTR®

1997 1001 WIRING

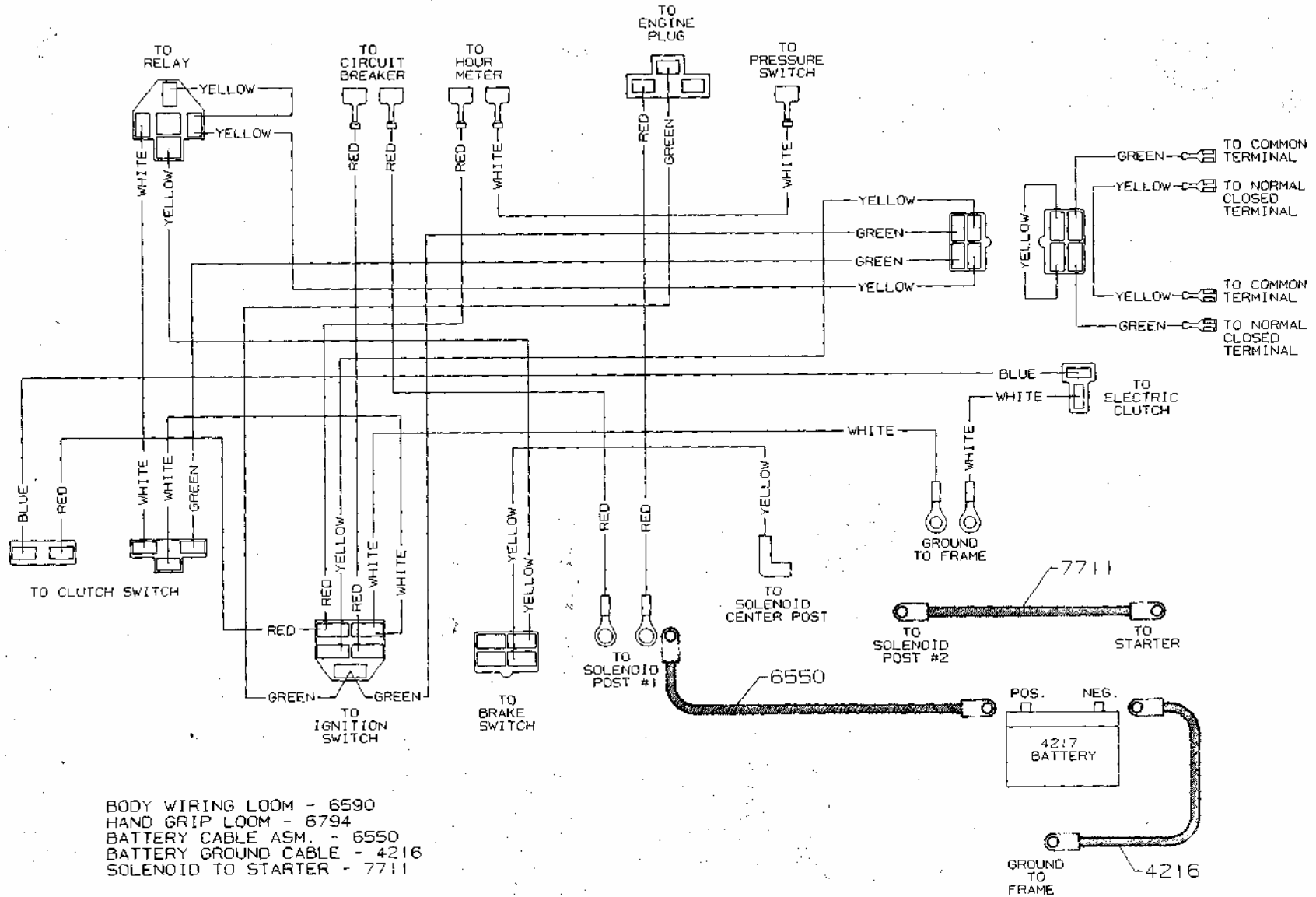

BODY WIRING LOOM - 6590
 HAND GRIP LOOM - 6794
 BATTERY CABLE ASM. - 6550
 BATTERY GROUND CABLE - 4216
 SOLENOID TO STARTER - 7711

WIRING KIT - 6805



 **WARNING:** The Engine Exhaust from this product contains chemicals known to the State of California to cause cancer, birth defects or other reproductive harm.

© Dixon and ZTR are registered trademarks of Dixon Industries, Inc.

Dixon Industries, Inc.
A **EMCO** International, Inc. Company
P.O.Box 1569
Coffeyville, KS 67337-0945
316-251-2000

Part No. 6798
November 1996
dng