



ZTR[®] Mowers

Operator's Manual

**5000
SERIES**

IMPORTANT - READ CAREFULLY

The Dixon ® ZTR ® Mower is both easy and fun to operate. However, any power mower must be operated properly to be safe. It is not a toy or a recreational vehicle. Before you start to use the mower, read the operator's manual carefully and become completely familiar with the controls.

The information in this operator's manual applies to all Dixon ® ZTR ©5000 Series Commercial Mowers. Your Dixon dealer will gladly answer any questions.

See your dealer for warranty service, parts and repairs.



DIXON INDUSTRIES, INC.
A BLOUNT International Inc. Co.
PO BOX 1569
COFFEYVILLE KS 67337 0945
316 251 2000

BLOUNT

INDEX

SAFETY	Pages	2-
WARRANTY POLICY	Page	8
SPECIFICATIONS	Page	9
SEAT ADJUSTMENT	Page	
CONTROLS	Pages	11-14
OPERATION INSTRUCTIONS	Pages	15-
CARE AND MAINTENANCE	Pages	23-
STANDARD SERVICE PARTS LIST	Page	39-
TROUBLESHOOTING	Pages	41-

SAFETY

*RIDING LAWNMOWERS, IF IMPROPERLY OPERATED,
CAN CAUSE SERIOUS INJURY OR DEATH*

The most common causes of injury to the operator or bystander...

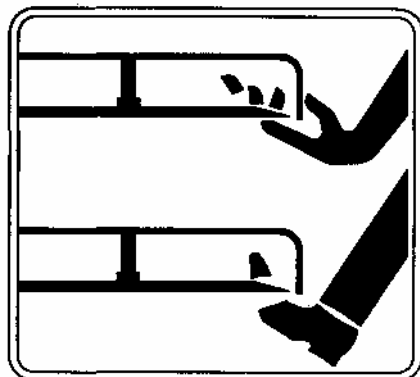

BLADE CONTACT

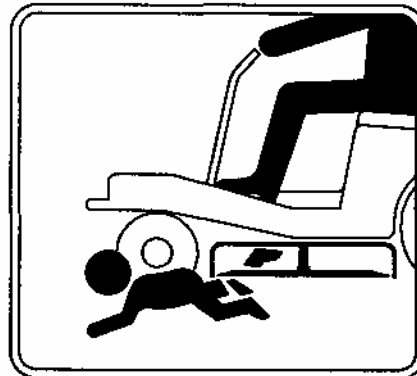

RUN-OVER

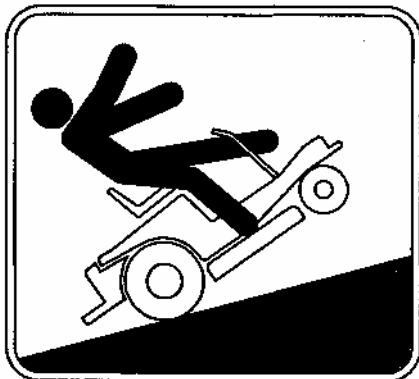

TIP-OVER

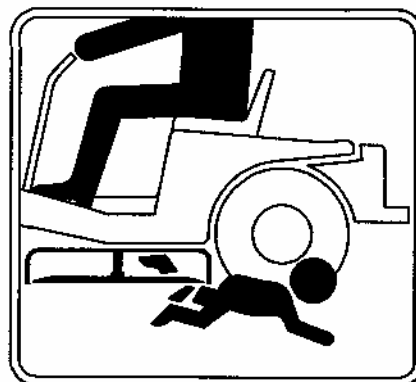

BACK-OVER

...read and understand this manual to prevent injuries.

 **SAFETY****SAFETY
SYMBOLS:****SAFETY ALERT SYMBOL -**

When you see this symbol,
BE ALERT to the potential for injury.

Follow recommended safety precautions and safe operating practices.



Danger indicates an imminently hazardous situation which, if not avoided, *will* result in death or serious injury.



Warning indicates a potentially hazardous situation which, if not avoided, *could* result in death or serious injury.



Caution indicates a potentially hazardous situation which, if not avoided, *may* result in minor or moderate injury. It may also be used to alert against unsafe practices.

 **SAFETY**

This cutting mower is capable of amputating hands and feet, and throwing objects. Failure to observe the following safety instructions could result in serious injury or death.

GENERAL OPERATION:

- Read, understand, and follow all instructions in the manual and on the mower before starting.
- Only allow responsible adults, who are familiar with the instructions, to operate the mower.
- Clear the area of objects such as rocks, toys, wire, etc., which could be picked up and thrown by the blade.
- Be sure the area is clear of other people before mowing. Stop mower if anyone enters the area.
- Never carry passengers.
- Do not mow in reverse unless absolutely necessary. Always look down and behind before and while backing.
- Be aware of the mower discharge direction and do not point it at anyone. Do not operate the mower without either the entire grass catcher or the deflector in place.
- Slow down before turning.
- Never leave a running mower unattended. Always turn off blades, set parking brake, stop engine, and remove key before dismounting.
- Turn off blades when not mowing.
- Stop engine before removing grass catcher or unclogging chute.
- Mow only in daylight or good artificial light.
- Do not operate the mower while under the influence of alcohol or drugs.
- Watch for traffic when operating near or crossing roadways.
- Use extra care when loading or unloading the mower into a trailer or truck. Do not ride the mower when loading & unloading.



WARNING: The Engine Exhaust from this product contains chemicals known to the State of California to cause cancer, birth defects or other reproductive harm.

 **SAFETY****SLOPE OPERATION:**

Slopes are a major factor related to loss-of-control and tip-over accidents, which can result in severe injury or death.

All slopes require extra caution.

If you cannot back up the slope or if you feel uneasy on it, do not mow it.

DO

Mow across the slope with your Dixon ZTR - never up or down.

Remove obstacles such as rocks, tree limbs, etc.

Watch for holes, ruts or bumps. Uneven terrain could overturn the mower. Tall grass can hide obstacles.

Use slow speed.

Use extra care with grass catchers or other attachments. These can change the stability of the mower.

Keep all movement on the slopes slow and gradual. Do not make sudden changes in speed or direction.

Avoid starting or stopping on a slope. If tires lose traction, disengage the blades and proceed slowly down the slope.

DO NOT

Do not turn on slopes unless necessary, and then, turn slowly and gradually downhill, if possible.

Do not mow near drop-offs, ditches, or embankments. The mower could suddenly turn over if a wheel is over the edge of a cliff or ditch, or if an edge caves in.

Do not mow on wet grass. Reduced traction could cause sliding. *Do*

not try to stabilize the mower by putting your foot on the ground. *Do*

not use grass catcher on steep slopes.

 **SAFETY****CHILDREN:**

Tragic accidents can occur if the operator is not alert to the presence of children.

Children are attracted to lawn mowers and the mowing activity.

NEVER assume children will stay where they were last seen.

Be alert to avoid accidents.

- Keep children out of the mowing area and under the watchful care of another responsible adult.
- Be alert and turn mower off if a child enters the area.
- Before and during backing, look behind and DOWN for small children.
- Never carry children. They may fall off and be seriously injured or interfere with safe mower operation.
- Never allow children to operate the mower.
- Use extra care when approaching blind corners, shrubs, trees, or other objects that may obscure vision.

 **SAFETY****SERVICE:**

- Use extra care in handling gasoline and other fuels. They are flammable and vapors are explosive.

Use only an approved container.

Never remove gas cap or add fuel with the engine running. Allow engine to cool before refueling. Do not smoke.

Never refuel the mower indoors.

Never store the mower or fuel container inside a building where there is an open flame.

- Never run a mower inside a closed area.
- Keep nuts and bolts, especially blade attachment bolts, tight and keep equipment in good condition.
- Never tamper with safety devices. Check their proper operation regularly.
- Keep mower free of grass, leaves, or other debris buildup. Clean up oil or fuel spillage. Allow mower to cool before storing.
- Stop and inspect the equipment if you strike an object. Repair, if necessary, before restarting.
- Never make adjustments or repairs with the engine running.
- Grass catcher components are subject to wear, damage, and deterioration, which could expose moving parts or allow objects to be thrown. Frequently check components and replace with original equipment parts, when necessary.
- Mower blades are sharp and can cut. Wrap the blade(s) or wear gloves, and use extra caution when servicing them.
- Batteries contain sulfuric acid. To prevent burns avoid contact with skin, eyes and clothing. To prevent a fire or explosion keep sparks and open flames away from battery.

Before disconnecting the negative (-) ground cable, make sure all switches are OFF.

DIXON LIMITED WARRANTY POLICY -- HYDRO-GEAR MODELS

This warranty policy applies to all HydroGear mowers or any 50" model, purchased on or after March 1,1990.

WARRANTY: Dixon Warranty term is for a period of one (1) year from date of purchase or 400 hours of use, whichever occurs first. Mowers used for residential homeowner applications (used only at owner's primary place of residence) are warranted for two (2) years from date of purchase or 400 hours of use, whichever occurs first. DIXON ZTR MOWERS ARE WARRANTED AGAINST DEFECTS IN MATERIALS AND WORKMANSHIP AND PROVIDES FOR REPLACEMENT OR REPAIR OF PARTS INCLUDING LABOR COSTS. THIS WARRANTY IS SUBJECT TO THE FOLLOWING CONDITIONS AND LIMITATIONS:

1. Warranty applies only to original retail purchaser of new and unused mowers and accessories.
2. All Dixon warranty must be accomplished by authorized Dixon dealers and in accordance with Dixon warranty policy and allowances. All warranty claims must be approved by Dixon Industries, Inc.
3. Battery warranty: Limited to 90 days from date of purchase.
4. Accessories Warranty (Grass Catchers, Snow Blades, Tine Rakes, Covers, etc.): Limited to 90 days from date of purchase.
5. Warranty does not apply to damage in transit or incidents of misuse, negligence, accidents, or alteration. The use of parts or components other than those supplied by Dixon Industries, Inc. VOIDS ALL WARRANTY.
6. The following items are not covered by this warranty policy:
 - (a) Pick up and delivery charges for transportation of mower to and from an Authorized Dixon Dealer's place of business.
 - (b) Routine maintenance or adjustments.
 - (c) Belts / chains / sprockets / cutting blades.
 - (d) Engines -- All engines used on Dixon ZTR mowers are warranted by each individual engine manufacturer.
 - (e) Any costs or expense of providing substitute equipment while repair work is being performed on a warranted mower.
7. There is no other express warranty. Implied warranties, including those of merchantability and fitness for a particular purpose, are limited to the same duration of the express warranty, and to the extent permitted by law any and all implied warranties are excluded. Liabilities for consequential damages under any and all warranties are excluded.

WARRANTY VALIDATION: At the time of sale, selling dealer must review each portion of this warranty document, complete the information section below, secure customer's signature and send copy to Dixon Industries, Inc.

DATE OF PURCHASE _____	Model _____	S/N _____
(Owner's Name) _____	(Dealership) _____	
(Address) _____	(Address) _____	
(Owner's Signature) _____	(Dealer's Signature) _____	

SEE DEALER FOR DETAILS

SPECIFICATIONS

Model ZTR 5022

CHASSIS:	11 GA - rectangular tube
BODY:	Two piece - made of high-density polyethylene. Front body contains access panels for battery service and engine to mower deck belt removal. Rear body tilts up to allow service on the entire drive system.
SEAT:	Economically designed for operator comfort, contoured back rest and arm rests. Seat is adjustable fore and aft.
MOWER DECK:	42" Deck: 13 GA Stamped Steel Construction - 42" Cut Width 50" Deck: 11 GA Fabricated Construction/Reinforcement Ribs - 50" Cut Width 60" Deck: 10 GA Stamped Steel Construction - 60" Cut Width Cut height approximately 1" to 4" via 7 position lift handle
BLADE DRIVE:	Electric clutch
DRIVE SYSTEM:	Each rear wheel is independently driven by a HydroGear BDU-10L Series 70 hydrostatic transmission. The hydrostatic transmissions, in turn, power a fully enclosed HydroGear gearbox.
ENGINE:	22HP Kohler Command, 4-Cycle, V-Configuration, Overhead Valve, Air-Cooled, Gasoline, Vertical Shaft, Aluminum Head, and Crankcase with Cast Iron Liners, Full Pressure Lubrication/Full Flow Filter, Pulse-type Fuel Pump, Fixed Jet Carburetor w/Smart-Choke, Electronic Ignition, In-Line Fuel Filter, Dual Element Air Cleaner.
STARTING SYSTEM:	Electric by key switch operation with safety interlocks on parking brake and blade drive clutch.
TIRES:	Front 11 X 4 X 5 ribbed tread Rear 20 X 10 X 8 Multi Trac
RECOMMENDED TIRE PRESSURE:	Front 16-21 lbs. Rear 8 -14 lbs.
CAPACITIES:	Fuel - 4.8 gallons total (dual tanks) Hydrostat oil tank - 3 quart with in-line filter Hydrostat oil recommendation, refer to page 35 Engine - 2 qts. SAE 10W30 (with filter)
DIMENSIONS:	Width 51 "(42" Deck), 60"(50" Deck), 72"(60" Deck) Height 45" Length 72" Weight 615 lbs.(42" Deck), 680 lbs.(50" Deck), 685 lbs.(60" Deck)
NOTE:	Additional information provided in service instructions under the individual component SPECIFICATIONS SUBJECT TO CHANGE WITHOUT NOTICE

SEAT ADJUSTMENT INSTRUCTIONS

Model ZTR 5022:

1. Set parking brake.
2. Raise upper body.
3. Loosen two front seat adjustment knobs and slide seat forward or backward to desired position.
4. Re-tighten front seat adjustment knobs.

DO NOT
*operate mower
without seat adjustments
properly tightened.*

5. Carefully lower upper body and seat assembly to the closed position.

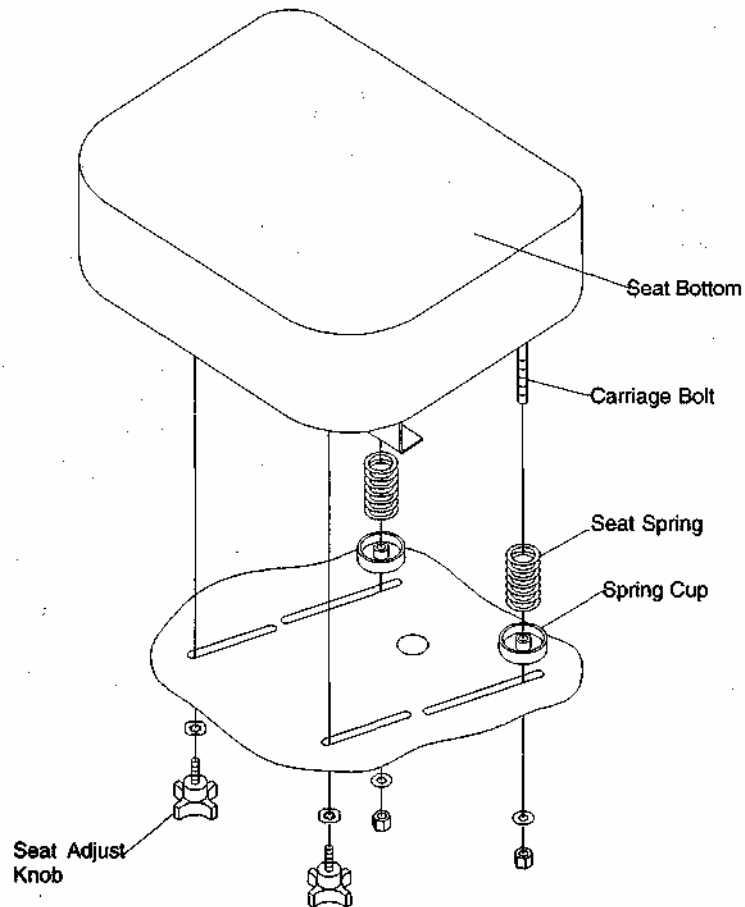

CONTROLS

5000 Series

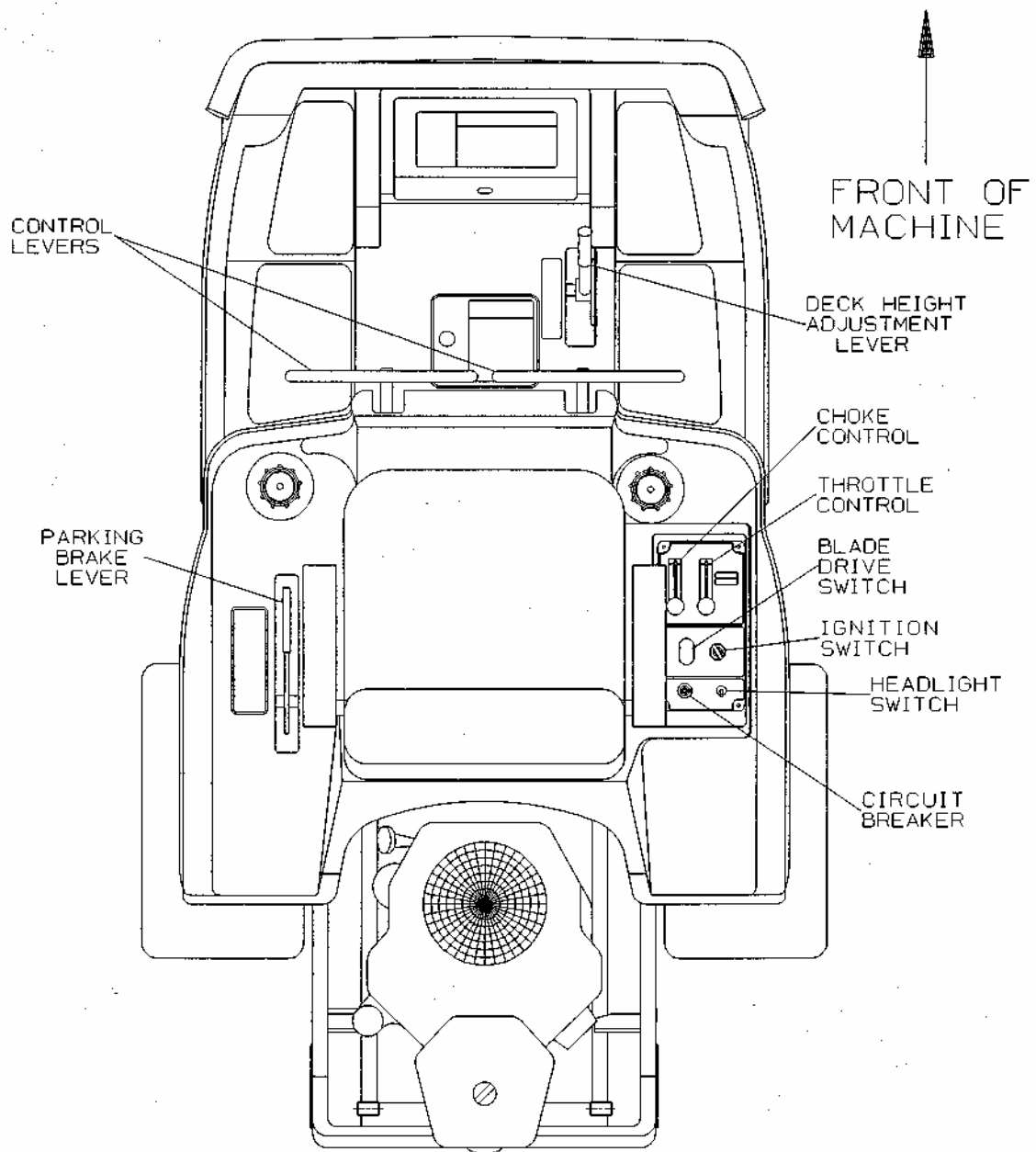

CONTROLS

PARKING BRAKE:

The parking brake used on the 5000 Series Models is designed to hold the mower from moving and is *not* intended for use in stopping the mower while it is in motion.

 **CAUTION** Engage parking brake before starting engine

Do not leave engine running for extended periods of time without the parking brake engaged. Damage to the drive system could result.

TO SET PARKING BRAKE:

The hand operated parking brake is located at left hand side of mower.

To engage brake, pull lever up and to the rear. To release brake, move lever forward and down. **NOTE:** Always set parking brake before dismounting. Release parking brake before moving mower.



HYDRO-GEAR DRIVE SYSTEM:

Allows the mower to turn on its own axis (zero turning radius).

Control levers control braking, turning, travel speed and direction. Each lever controls one side of the mower.

NOTE: The pressure required to operate the mower is very light.

First-time operators should spend a minimum of 1/2 hour driving the mower without the blade drive engaged to become familiar with the controls.

CONTROLS

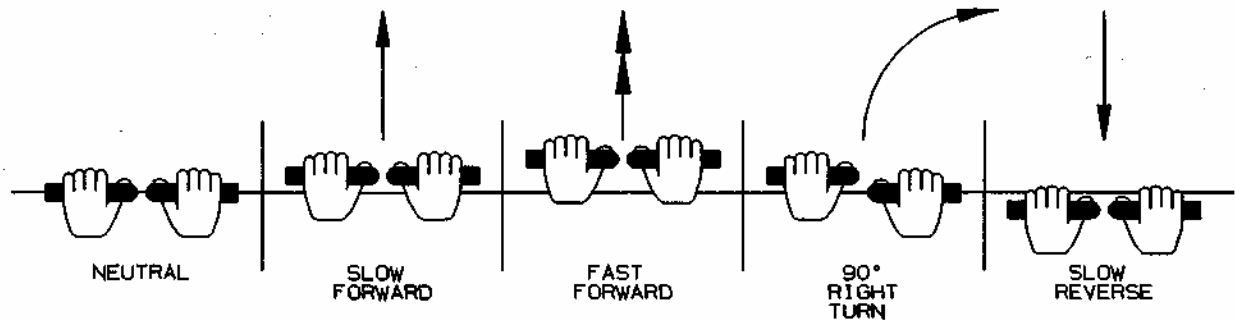

TO GO FORWARD:

From neutral position, gently push both drive levers forward.

To increase speed, move levers farther forward.

TO GO BACKWARD:

From neutral position, gently pull both drive levers toward you.

TURNING:

Turning is controlled by moving one drive lever slightly forward or rearward of the other.

To turn left, move left lever rearward of the right lever.

To turn "square corners" move lever of desired direction to neutral.

To turn on mower's own axis (zero turning radius) stop and move one lever to reverse position and the other to forward position.

BRAKING:

To brake mower, move both levers in direction opposite of travel, release levers to neutral, set parking brake. Park only on level surfaces.

CHOKE CONTROL LEVER:

Located on control panel to operator's right.

Used to start a cold engine.

THROTTLE CONTROL LEVER:

Located on control panel to operator's right.

Controls engine speed, slow to maximum.

While mowing, throttle control should be set to the MAXIMUM or wide open setting to insure adequate cooling of the engine and to maintain mower deck blade speed.

BLADE DRIVE:

CONTROLS

Located on control panel, on operator's right.

1998 Models

To engage blades: Slide switch to rear and flip up and forward.

To disengage blades: Flip switch down.

1999 Models

To engage blades: Pull switch up.

To disengage blades: Push switch down.

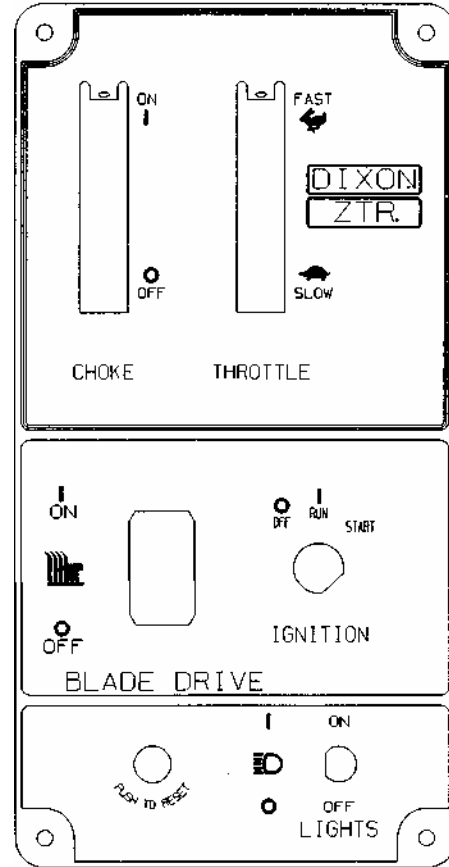

CIRCUIT BREAKER:

Located on control panel, on operator's right.

Protection of the electrical system is by (1)15 amp circuit breaker.

If circuit breaker trips, push button to reset.

If this condition repeats, consult dealer for inspection and repair.

MOWER DECK CUT HEIGHT LIFT LEVER:

Located to the right and front of operator. Controls the cutting height. Seven positions of adjustment.

Depress trigger and move lever forward to lower deck.

Depress trigger and pull lever back to raise deck.

NOTE: Always use high position for transport.



OPERATION INSTRUCTIONS

The safe and successful operation of the 5000 Series Models will depend upon the operator having the correct knowledge of all controls used on the mower and making good judgements about the terrain to be mowed.

NEVER allow anyone to operate the mower without complete knowledge of all controls and their functions.

First-time operators should set throttle at slow speed while learning to drive.

Sound judgement by the owner will prevent accidents.

BEFORE OPERATING MOWER:

1. Read engine manufacturer's operating and maintenance instructions.
2. Discuss proper maintenance with your dealer.
3. Read and observe all safety instructions on your mower and in the manual.
4. Check engine oil.
5. Check gas cap to be sure it is in place.
6. Be sure parking brake is on.
7. Be sure mower blade drive is off.
8. Know how to stop engine. (Turn key to off position)

OPERATION INSTRUCTIONS



TESTING OF SAFETY INTERLOCK SYSTEMS:

PARKING BRAKE SWITCH TEST: With parking brake in the OFF position, engine should not turn over or attempt to start when the key switch is moved to the start position.

BLADE DRIVE SWITCH TEST: (5000 Series)

- a. With electric blade drive switch turned ON and parking brake in the ON position, engine should not turn over or attempt to start when key switch is moved to the start position.
- b. In a SAFE AREA away from bystanders, start the engine, place throttle setting at maximum or full. Engage the blades by turning the blade drive switch to the ON position. Raise weight slightly off of seat. *Engine should stop.*
- c. *If any Safety Check fails, do not operate the mower until the system has been checked and repaired by an Authorized Dixon ZTR Dealer.*

OPERATION INSTRUCTIONS

STARTING INSTRUCTIONS: Cold Engine

1. Position choke control in ON position.
2. Position throttle control at 1/2 speed setting.
3. Insert ignition key and turn to "Start" position. When engine starts, release ignition key. Key will return to "Run" position.
4. Once engine starts to *warm up*, slowly move choke control to OFF position.
5. Move throttle control to the *FAST position* for actual operation of the mower deck.
6. Engine must be operated with throttle control in the FAST position, *or maximum* setting to insure adequate lubrication and cooling of the engine, and cut quality of the mower deck.

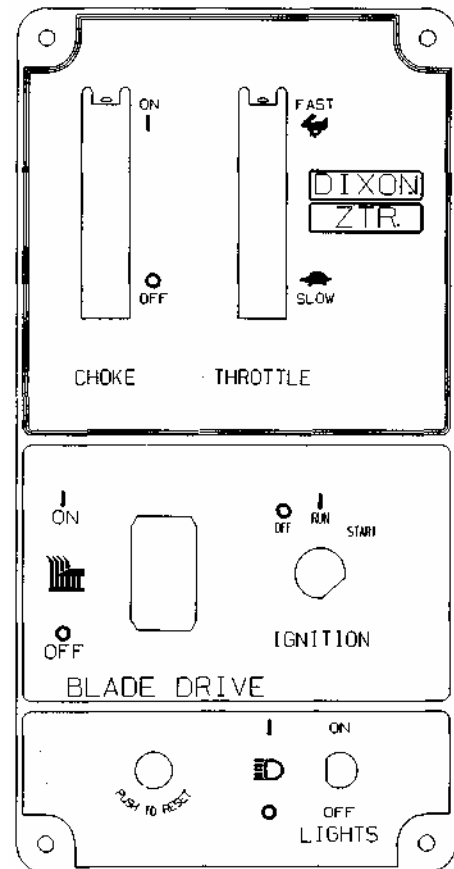

OPERATION INSTRUCTIONS

STARTING INSTRUCTIONS: Engine has been operated.

1. Move throttle control to 1/4 to 1/2 setting.
2. Insert ignition key and turn to "Start" position. When engine starts, release ignition key. Key will return to "Run" position.
3. Move throttle control to FAST position for actual operation of the mower deck.

NOTE: Model ZTR 5022 may require partial choke setting to start even if the engine has been operated for a period of time.

4. Engine must be operated with throttle control in the FAST position, or maximum setting to insure adequate lubrication and cooling of the engine, and cut quality of the mower deck.

A CAUTION

DO NOT operate the engine in an enclosed area due to the harmful exhaust gas produced.

NOTE: On initial operation, set throttle at slow speed.

Engine cannot be restarted when blade is engaged.

Safety switches stop engine when operator leaves seat while mower blade is engaged.

Always turn engine off when leaving mower.

OPERATION INSTRUCTIONS

MOWING WITH A MULCHING ATTACHMENT:

Mulching or recycling the grass clippings requires a totally different mowing approach than would be normal when side discharging or bagging the grass. There may be instances or conditions where it is not possible to hide all of the recycled or mulched clippings.

In order to achieve the best results, please read and follow the mulching tips listed below:

1. Set the engine speed control to the wide open or full setting.
2. Place the mower deck cut height selector in either the top or second notch. Never cut more than 3/4" to 1" off the grass at any one time. Attempting to cut more grass will result in the deck plugging and cause the engine to stall.
3. It may be necessary to cut the lawn twice to achieve acceptable mulching performance especially on first cuttings or if the lawn is heavily fertilized.
4. *Do Not Attempt To Cut Grass When It Is Wet.* Mulching performance will be very poor under wet grass conditions.
5. *Maintain Sharp Blades Throughout The Cutting Season.* This is very important. Optimal mulching performance cannot be obtained with dull or nicked blades.
6. *Keep The Underside Of The Mower Deck Clean.* Remove all grass and dirt buildup from the underside of the pan, the baffles and deflectors after each use.
7. Alternate mower direction. This will evenly disperse the mulched grass clippings over the lawn for even fertilization.

If the mulching quality of the mower does not seem to be satisfactory, try one or more of the following tips:

1. Raise the height-of-cut setting on your mower.
2. It may be necessary to cut your grass more frequently.
3. Operate the mower at a slower ground speed.
4. Overlap cutting swaths instead of cutting a full swath with each pass.
5. Mow across the marginal areas a second time.
6. CUT HIGH - MOW OFTEN!

OPERATION INSTRUCTIONS

MOWING WITH A GRASS CATCHER ATTACHMENT:

In order to achieve optimum performance when mowing with a grass catching attachment, please read and follow the tips listed below:

1. Set engine speed control to the wide open or full setting.
2. *Do Not Attempt To Cut Grass When It Is Wet.* Wet grass will clog both the underside of the deck and the attachment chutes. Empty bags often to prevent plugging.
3. If the grass is tall, place the mower deck cut height selector in the top or second notch. Initially overlap cutting swaths instead of a full swath with each pass.
4. *Keep The Underside Of The Mower Deck Clean.* Frequent removal of dried grass and dirt will greatly assist in bagging of the clippings.
5. Use only the correct blades. Some grass catching attachments require a "high-lift" blade. See your dealer for advice on the type of blades needed for your mower.
6. *Maintain Sharp Blades Throughout The Cutting Season.*
7. Operate the mower at a slower ground speed than when mowing without a grass catching attachment.

CAUTION

- Watch for low hanging branches or other obstacles which might hit the catcher top while turning or backing the mower.
- Use care when backing to avoid pushing the grass bags into the frame or hot exhaust muffler of the engine.
- Disengage blade and stop engine prior to clearing grass from either the discharge chute or grass catcher components.
- Keep all attachment bolts tight.
- *Do Not* operate the mower with the grass catching attachment partially removed.

Important:

Do not leave clippings in the bags while the mower is stored.
Damp grass clippings are a fire hazard if left in the bags.

OPERATION INSTRUCTIONS

SIDE DISCHARGE OF THE CLIPPINGS:

In order to achieve optimum performance when side discharging the grass clippings, please read and follow the tips listed below.

Additional information can be found in the troubleshooting guide on page 40.

 **CAUTION** Be sure that deflector is properly installed on the discharge chute.

1. Set engine speed control to the wide open or full setting.
2. *Do Not Attempt To Cut Grass When It Is Wet.* Wet grass will clog the underside of the deck and discharge area.
3. If the grass is tall, place the mower deck cut height lever in the top or second notch. Initially overlap cutting swaths instead of a full swath with each pass. Some applications may require a second cutting.
4. *Keep The Underside Of The Mower Deck Clean.* Frequent removal of dried grass and dirt will allow the clippings to discharge correctly.
5. *Maintain Sharp Blades Throughout The Cutting Season.*

GRASS HEIGHT SUGGESTIONS:

Correct mowing height can reduce weeds and disease by 50% to 80%

The following grass cut heights are based on adequate moisture conditions and normal thatch buildup in a healthy lawn. Some locations and applications may require slightly different cut heights. If in doubt, consult your local lawn professional for assistance.

Grass Types:	Best Cut Heights:
Zoysia	2" - 2 1/2"
Blue Grass	1 1/2" - 3"
Fescue Blends	1 1/2" - 3"
St. Augustine (Mid South)	1 1/2" - 2"
St. Augustine (Deep South)	3" - 4"
Tifton Bermuda	1 1/2"
Centipede	1 1/2" - 2"
Common Bermuda	1 1/2" - 2"
Bahia/Argentina/Pensacola	2"

OPERATION INSTRUCTIONS

DECK ROLLERS: 60" Deck

- Purpose:** The spring loaded deck rollers located at the front corners of the 60" mower deck are designed as an aid to limit turf scalping when mowing on uneven ground.
- Height:** Normal height settings as installed at the factory allows each roller to ride slightly above the turf. This setting should prove ideal under most mowing conditions.
- Adjustment:** Some mowing applications may require lowering of each front roller. To lower the roller, remove the pin, spring, washers and spacer P/N 9789 from the top of roller bracket tube. Remove roller bracket from tube. Slide spacer P/N 9789 on roller bracket shaft and reassemble using washer, spring and pin at the top.
- Lubrication:** The use of a penetrating oil or light grease on the roller bracket shafts will keep roller moving freely.

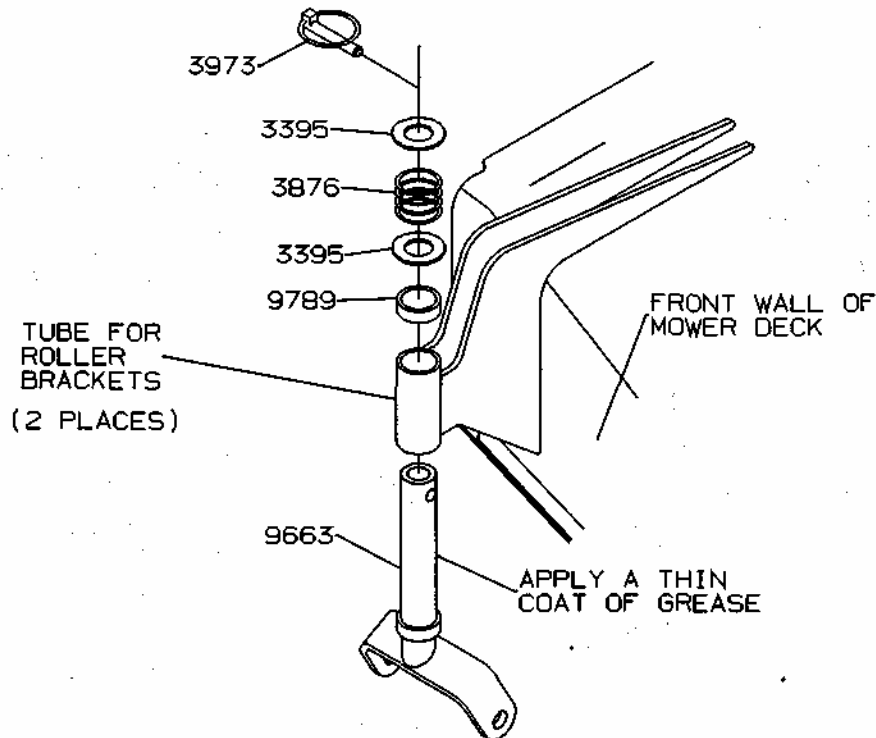

CARE AND MAINTENANCE

This portion of the 5000 Series Models owners manual deals with normal service items which can be performed by the owner. Please remember that if you are in doubt as to the correct service procedures to be followed, these and other service situations can be handled by a Dixon ZTR dealer who is familiar with the service of your mower.

MAINTENANCE SCHEDULE:

To insure a long and trouble free service life on all the components used on the 5000 Series Models, a regular and thorough maintenance schedule should be followed. The following items should be checked after the first (10) hours of operation and on a weekly basis, or each (40) hours of use: (Items marked with an asterisk * require more frequent attention)

1. Drive system, belts and controls.
2. Mower deck belts.
3. Tire pressures.
4. HydroGear oil tank.
5. Tightness of all nuts and bolts.
6. Battery fluid level.
7. * Engine oil. (Before each use or every 8 hours)
8. Electric blade clutch air gap setting.

CAUTION

**Before performing any maintenance,
shut off engine, allow to cool.**

ENGINE: For engine operating and maintenance information, refer to the engine operating and maintenance instructions furnished by the engine manufacturer, supplied with each mower.

BATTERY: Check the fluid in the battery at frequent intervals.
Keep fluid level above the plates in each cell, using distilled water.

OFF-SEASON BATTERY STORAGE:

Identify each cable so cables can be reconnected to correct terminals.

Disconnect cables from terminals.

ALWAYS disconnect ground cable first and reconnect last.

Charge battery.

DO NOT remove battery from mower.

Clean top of battery and terminals with baking soda and water.

CARE AND MAINTENANCE

MOWER BLADE MAINTENANCE:

NOTE: Observe proper blade position prior to removal.

1. Safely raise front of mower.
2. Hold or block blade from turning.
3. Loosen blade nut and remove blade.

⚠ CAUTION Wear heavy, thick gloves when holding onto mower blade, avoid the sharp edge of the blade.

4. Tighten blade nut securely. Refer to diagram.

NOTE: Be sure blade is centered on pilot before tightening bolt to 60 ft. lbs. torque.

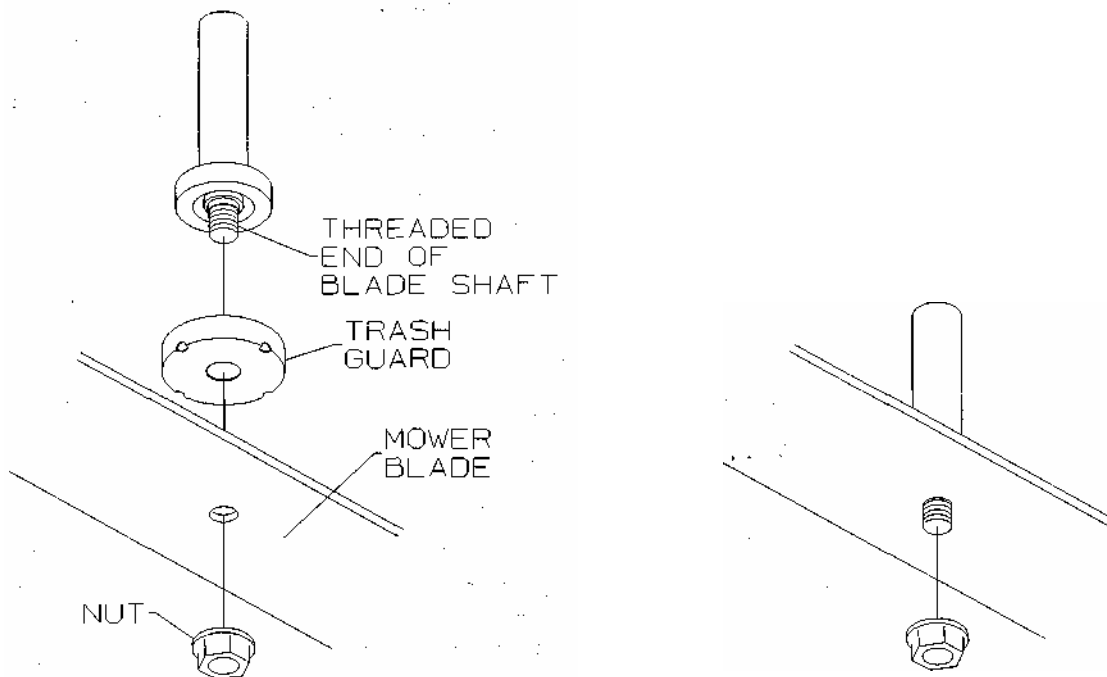

CARE AND MAINTENANCE

ENGINE TO MOWER DECK BELT:

42' and 50"	P/N 6111
60"	P/N 6938

The engine to mower deck drive belts are automatically held in proper tension by springs which push the deck assembly forward and do not require any additional adjustment to be made.

MOWER DECK SERPENTINE BELT:

42"	P/N 6109
50"	P/N 1300
60"	P/N 6939

Refer to illustration for adjustment procedure.

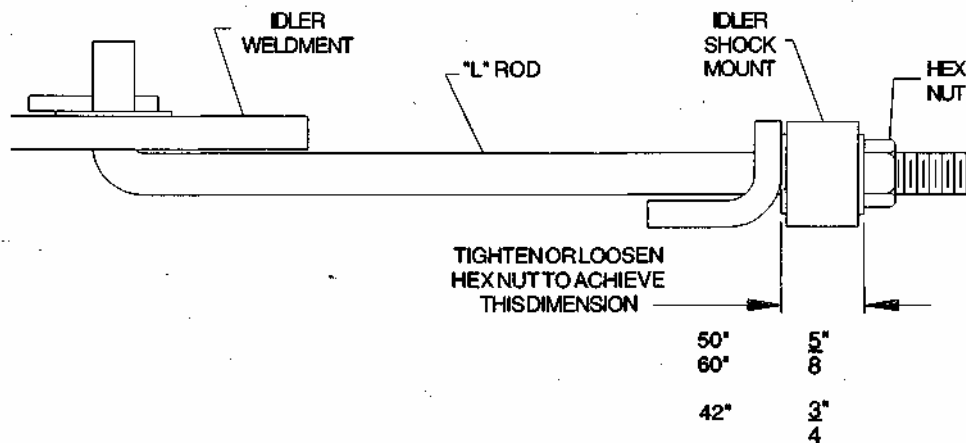

NOTE: Belt deflection or movement should be approximately 1/4" when measured at mid-point between pulleys.

Periodically inspect both belt and idler systems.

CARE AND MAINTENANCE

FUEL SHUT OFF VALVE:

A fuel shut off valve is located at the bottom rear of each fuel tank.

Always turn the valve to the "OFF" position when the mower is stored or not in use.

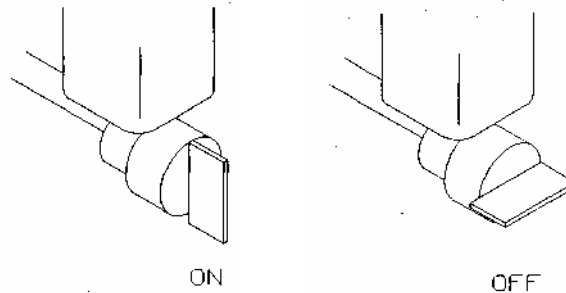

LUBRICATION

CHASSIS:

Number of grease zerks used: (5)

LOCATIONS:

(1) each front wheel caster tube
(1) each mower deck hub

SERVICE INTERVALS:

Every 50 hours of operation

RECOMMENDED GREASE:

Name brand wheel bearing or multi-purpose grease

Adequate lubrication of the caster tubes and mower deck hubs will help dispel moisture from within the bearing retention areas. Bearings are of a sealed design.

CARE AND MAINTENANCE

5000 SERIES REAR WHEELS:

The rear wheels of all 5000 Series models are of an "offset" center design to allow "reversed" installation for using snow chains or to gain increased stability when mowing on sloped ground.

Slopes are a major factor related to loss-of-control and tip-over accidents, which can result in severe injury or death. All slopes require extra caution. If you cannot back up the slope or if you feel uneasy on it, do not mow it.

WHEEL REVERSAL:

* Installation instructions marked with an * asterisk are particularly important.

1. Raise rear of mower and place suitable supports at the rear of the chassis.
2. Remove rear wheel lug nuts and rear wheels.
3. Reinstall rear wheels with valve stems inward.
- 4.* Install lug nuts with "flat" side of nut against wheel.
- 5.* Tighten lug nuts to a minimum torque factor of 50 ft. lbs.

CARE AND MAINTENANCE

CAUTION

HOT oil may cause burns.
Allow engine to cool before draining oil.

CHANGING THE ENGINE OIL:

1. The "snap lock" oil drain valve is located on the left side of the engine crankcase.
2. Place a suitable container under the drain valve. The short piece of hose will help direct the oil.
3. *Push* the valve body in and *twist* to clear the detent notch.
4. *Pulling* the valve body outward will start the flow of oil.

NOTE: Refer to engine manufacturers recommendations for frequency of oil changes.

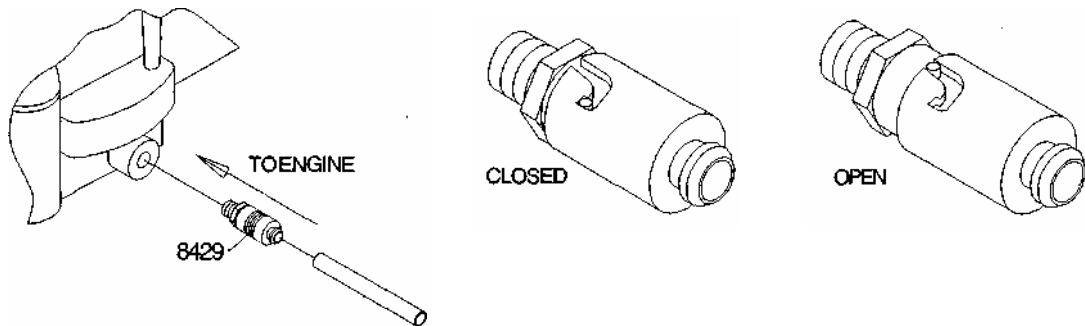

OIL FILL:

1. Push the valve body in and twist into the detent notch.
2. Clean any spilled oil from engine and chassis.
3. Refill engine with type, and quantity of oil recommended by the engine manufacturer in engine literature.

NOTE: Engine oil changes on the 5000 Series Models will require replacement of the oil filter. These filters can be obtained from any authorized Kohler engine dealer.

PROTECT YOUR INVESTMENT:

The use of non-original oil or air filters may result in damage to the engine and a loss of warranty. Listed on page 38 are the correct part numbers for each engine in the 5000 Commercial Series.

*PLEASE DISPOSE OF USED OILS AT PROPER COLLECTION CENTERS
PROTECT YOUR ENVIRONMENT*

CARE AND MAINTENANCE

MOWER DECK REMOVAL:

1. Remove mower deck drive belt. To relieve belt tension, insert 5283 link (at front of lift frame) into tab illustrated below. Move lift handle into the lowest cut position. Belt can now be removed from mower deck pulley.

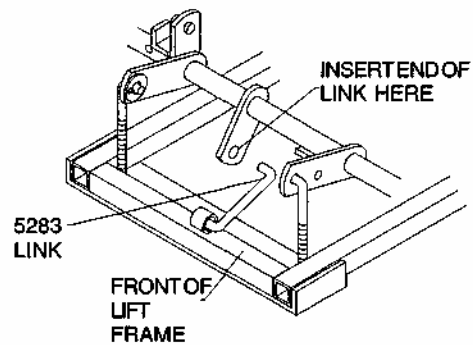

2. Remove front and rear deck hanger pins, as illustrated below.

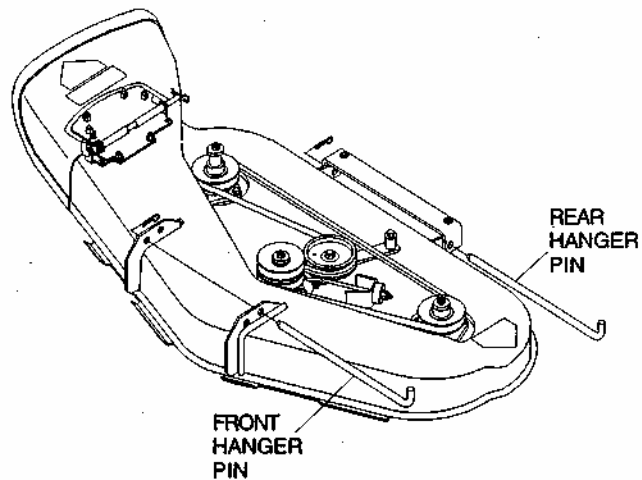

3. Slide deck from beneath chassis.
4. Reverse procedure to reinstall deck to chassis.

CARE AND MAINTENANCE

MOWER DECK LEVELING PROCEDURE:

There are a total of (4) threaded adjusters which will control the attitude or pitch of the mower deck. The adjusters have lock nuts on the bottom which can be turned up or down to raise or lower the front and rear of the mower deck. Deck should be level or pitched slightly higher in rear.

- A. Place the mower on a smooth level surface, check tire pressures to insure the mower has a correct stance. Inflate tires as required:

Front: 16 - 21 lbs maximum
Rear: 8-14 lbs maximum

- B. Turn each outer blade tip to align with the deck or in a side to side manner.
- C. Measure from the floor surface up to the bottom of the blade tip on the discharge side of the mower deck. Retain this measurement. Move to the opposite side, check that measurement is the same. If adjustment is required, turn the nut on the bottom of the front threaded adjuster up or down until both side to side measurements are equal. Retain measurement.
- D. Turn both outer blades to align with the deck in front to rear manner. Turn left rear adjuster nut up or down until rear of mower deck is positioned level to 1/8th of an inch higher in the rear than the side to side measurement. At this time, the mower deck will be suspended on (3) points (both front adjusters and the left rear adjuster). Move the right rear adjuster and take out the slack which will be present by turning adjuster lock nut up.
- E. Confirm measurements once again. Blade tips should be level in a side to side manner. In the rear, blade tips should be level to 1/8" higher than side to side measurement. In the front, blade tips should be level to 1/8" lower than side to side measurement.

NOTE: This will place the mower deck in a base measurement position. Additional adjustment may be required to achieve desired cut for the type of grass or conditions being mowed.

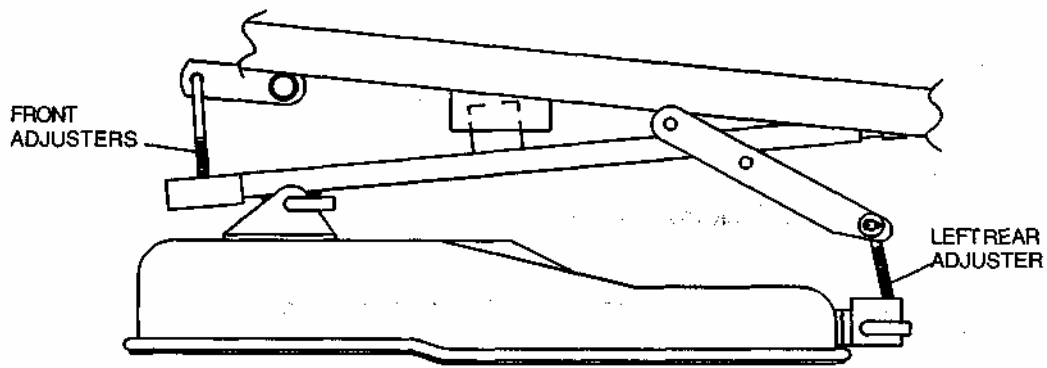

DECK LEVELING ADJUSTMENT POINTS

CARE AND MAINTENANCE

Adjustment of the drive system is limited to the actual function of the hydrostatic transmissions as outlined below.

T-BOX TO HYDROSTAT BELT ADJUSTMENT:

Tighten the (2) J-bolts on the T-box mounting plate until each belt has 1/8th to 1/4th of an inch free play or movement at a mid-point between the pulleys on the hydrostats and T-box.

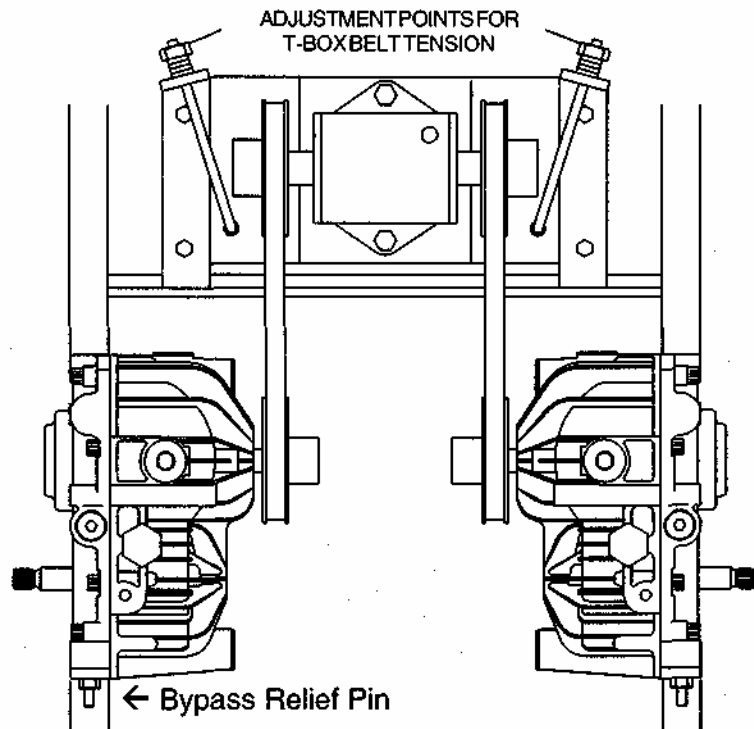

Each hydrostat has a bypass relief pin located at the rear of the hydrostatic unit. A bypass keeper is provided to allow the mower to be rolled around without engine running. To accomplish this, the bypass keeper springs must be positioned to depress the bypass relief pins. Remove bypass keeper springs prior to actual operation of the mower.

CARE AND MAINTENANCE

PARKING BRAKE CABLE ADJUSTMENT:

Make necessary adjustments to the T-Box to Hydrostat belt, as shown on page 30.

Position parking brake lever in the off or disengaged position.

This will allow the belt idler used on the engine to T-box to swing fully and apply tension to the belt.

At this time, check that the cable has approximately 1-1/2 to 2 inches of free play.

If adjustment is required, turn the lock nut illustrated below to achieve a recommended 1-1/2 to 2 inches of free play.

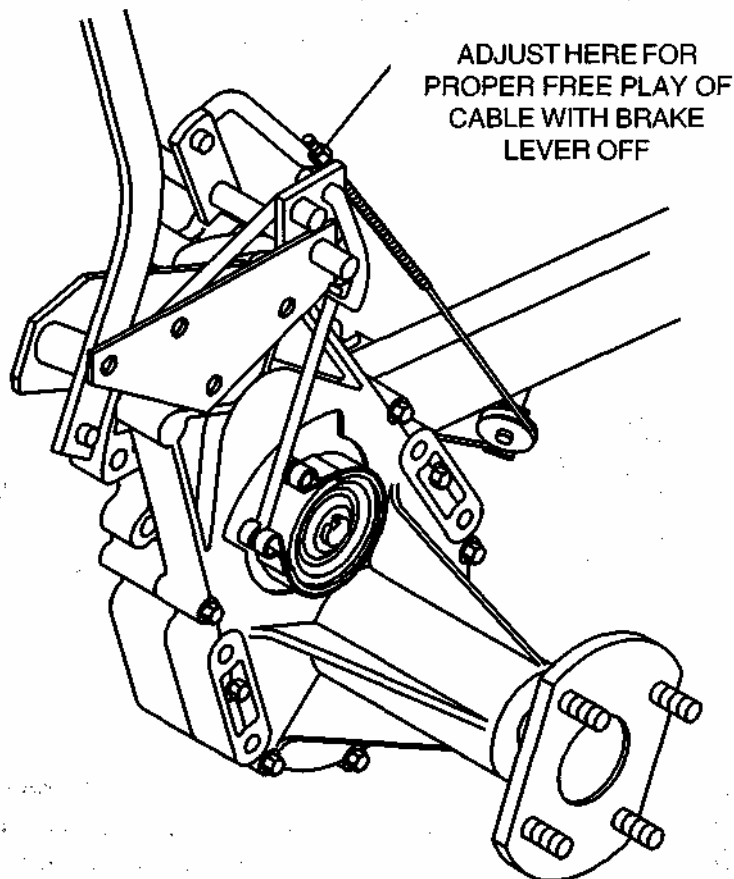

NOTE: Cable must have the recommended 1-1/2 to 2 inches of free play with parking brake released or drive belt may slip, causing loss of power.

CARE AND MAINTENANCE

NEUTRAL ADJUSTMENT:

1. Engage parking brake, and raise rear of frame with jack or blocks so that rear tires do not contact the ground.
2. Swing out the control levers, start the engine, and release the parking brake.
3. Raise the upper body to access hydro control linkage. If right wheel creeps, adjust right side linkage and vice-versa. Use procedure below:
 - a. loosen, but do not remove, the bolt in the control tube (5540)
 - b. loosen jam nuts on ends of the control rod (9067)
 - c. turn control rod in or out until neutral is achieved
 - d. tighten jam nuts on control rod
 - e. tighten bolt in control tube

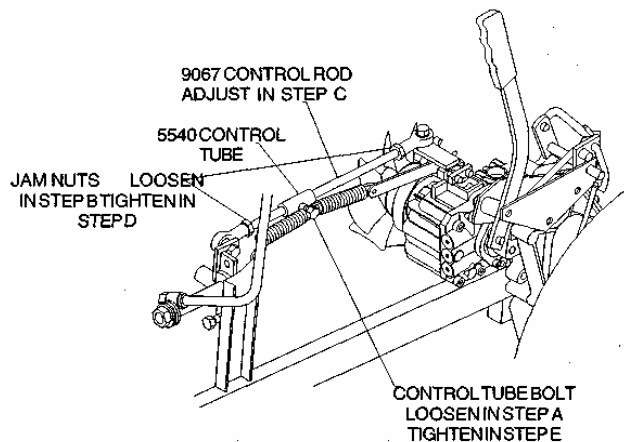

4. Engage parking brake and lower the body.
Release parking brake and swing control levers in. If wheel creeps, repeat step 3.
4. Stop engine and remove rear of machine from jack or blocks.

CARE AND MAINTENANCE

6. Drive machine with both levers in top speed position. If one side now drives slightly faster than the other adjust forward speed bolt in to contact stop sooner.

If levers are now uneven at top speed, loosen control lever mounting nut. Rotate lever to be even with other side and tighten nut.

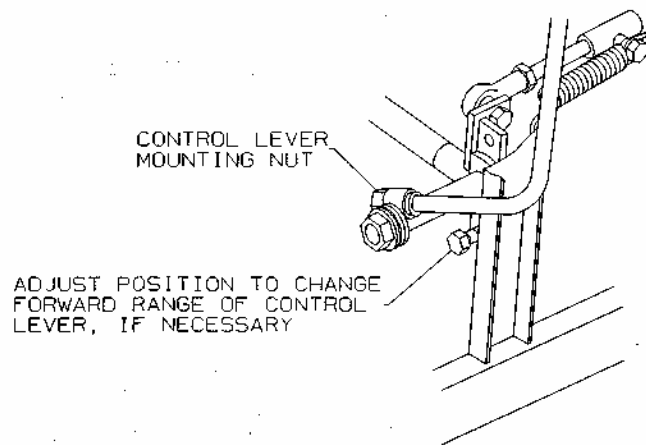

FORWARD TRAVEL SPEED ADJUSTMENT:

1. Drive machine on a smooth, level surface with both levers in top speed position.
2. If one side drives slightly faster than the other, adjust forward speed bolt in to contact stop sooner. If levers are now uneven at top speed, loosen control lever mounting nut. Rotate lever to be even with other side and tighten nut.

CARE AND MAINTENANCE

PROCEDURE FOR ELECTRIC CLUTCH ADJUSTMENT

Electric clutches require periodic Air Gap adjustments for extended life. Listed below is both an Air Gap adjustment procedure and an Ohms test to check for a faulty coil within the clutch. No replacement parts are available to repair a faulty assembly. The entire clutch must be replaced.

A. AIR GAP ADJUSTMENT

1. Remove the clutch from the engine. This is recommended because it is easier to verify the gap.
2. Locate the three rivet joints which fasten the leaf springs to the armature, (figure 1)
3. Rotate the pulley until these rivet joints are located midway along the edge of the triangular field adapter, (figure 1)
4. Locate the three holes in the brake plate, one near each adjustment nut. (figure 2)
5. Insert a .012 inch feeler gauge into one of the three windows. Be careful to position the feeler gauge between the rotor and armature faces, (figure 3)

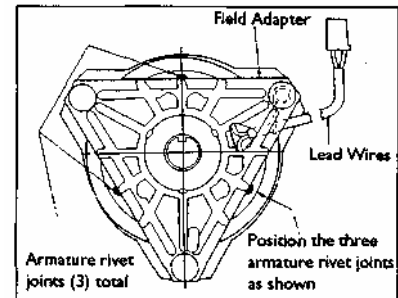

figure 1

6. Tighten the adjusting nut adjacent to the window with the feeler gauge inserted until the gauge fits snugly between the rotor and armature. The gap should not be so tight that the feeler gauge cannot be reinserted after removal.
7. Repeat Steps 5 and 6 at the other two windows.
8. Re-check the air gap at each window and make minor adjustments as necessary to achieve a consistent .012 inch air gap.
9. Reinstall the clutch to the engine. Be sure to torque the mounting bolt back to 50 ft. lbs.

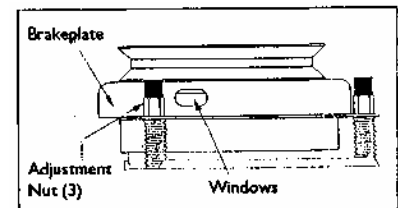

figure 2

B. OHMS TEST

1. Disconnect clutch from mower wiring harness.
2. Attach the two leads on multi-meter to the two wires coming from the electric clutch.
3. The reading you receive should be between 2.4 to 2.9 OHMS.
4. If the resistance is outside this range the clutch coil is faulty.
5. If the clutch coil is faulty, the clutch must be replaced.

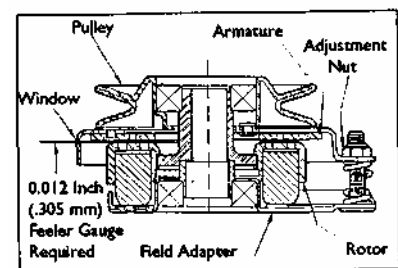

figure 3

CARE AND MAINTENANCE

HYDROSTATIC TRANSMISSION OIL AND FILTER SERVICE

SERVICE INTERVALS:

1. Initial oil and filter service - 50 hours.
2. Every 250 hours thereafter.

OIL REQUIREMENTS: Any high quality engine oil with an API classification of SG/CD is recommended.

RECOMMENDED OIL WEIGHT: Normal operation temperatures - 20 W 50
Cold climate usage - 10 W 40
Another alternative that will provide excellent all climate performance and extended time between oil changes is a 15 W 50 synthetic engine oil.

OIL FILTER: *P/N 7252- IMPORTANT*

The oil filter is a special design for use on "vacuum or suction" oil flow systems.

DO NOT: Use automotive engine oil filters. These filters require a "pressure" to allow oil flow. Usage will result in an "air-lock" condition with possible damage.

CARE AND MAINTENANCE

HYDROSTATIC TRANSMISSION OIL AND FILTER SERVICE

If transmission is to be serviced, proper air purging procedures must be followed, or damage will occur. Proceed as follows:

1. Remove oil filter from chassis, allowing oil to drain into container. Clean impurities from inside of reservoir, if necessary.
2. Install new oil filter to chassis. Use only genuine Dixon replacement oil filter.
3. Put fresh oil in reservoir. Fill reservoir to the full mark.
4. Remove two oil return hoses from top of oil reservoir and direct these hoses into a container for oil draining.
5. Depress by-pass valve on both hydros.
6. Start engine and move throttle to mid-range setting.
7. Release parking brake.
8. Dirty oil, filled with air bubbles, will start to drain from oil return hoses into container. When oil flowing from hoses is clear and contains no bubbles, stop the engine.
9. Reattach oil return hoses to top of reservoir.
10. Release by-pass valve on both hydros.
11. Add sufficient oil to reservoir to return oil level to the full mark.

CARE AND MAINTENANCE

WHEELS AND TIRES: Correct tire pressure is important for correct operation of mower.

Air Pressure 16-21 lbs. (Front)

Air Pressure 8-14 lbs. (Rear)

NOTE: Check lug nuts periodically for tightness.

ELECTRICAL SYSTEMS: Keep all connections clean and tight.

CLEANING THE MOWER: Wash mower periodically.

Clean above and below deck.

NOTE: Allow mower to cool before washing. If bearings are hot, they will draw moisture inside as they dry and cause corrosion.

SERIAL NUMBERS: The serial number is located on frame at rear of engine.

WARRANTY: Refer to Warranty Registration Form (P/N 8289).

PARTS/SERVICE: See your Dixon dealer for replacement parts, warranty or service.

*PLEASE HELP PROTECT THE ENVIRONMENT BY AVOIDING ALL
CHEMICALS WHICH MAY DAMAGE OR CAUSE HARM TO PLANTS AND
ANIMALS IN YOUR AREA*

STANDARD SERVICE PARTS LIST

42" DECK

BLADES:	LoLift:	P/N 6236
	Standard Hi-Lift:	P/N8688

BELTS:	Engine To Mower Deck:	P/N6111
	Serpentine Belt:	P/N6109
	Engine To T-Box:	P/N 171 4(1 998 models)
	Engine To T-Box:	P/N 7253(1 999 models)
	T-Box To Hydros:	P/N 1765

50" DECK ^{K⁵}

Grass Blower Belt:	P/N 4983
--------------------	----------

BLADES:	Lo Lift:	P/N 9443
	Standard Hi-Lift:	P/N 9444

BELTS:	Engine To Mower Deck:	P/N 6111
	Serpentine Belt:	P/N 1300
	Engine To T-Box:	P/N 1714(1998 models)
	Engine To T-Box:	P/N 7253(1 999 models)
	T-Box To Hydros:	P/N 1765

Grass Blower Belt:	P/N 4983
--------------------	----------

60" DECK

BLADES:	Hi-Lift:	P/N 9445
---------	----------	----------

BELTS:	Engine To Mower Deck:	P/N 6938
	Serpentine Belt:	P/N 6939
	Engine To T-Box:	P/N 1714(1998 models)
	Engine To T-Box:	P/N 7253(1 999 models)
	T-Box To Hydros:	P/N 1765

STANDARD SERVICE PARTS LIST

KOHLER AIR AND OIL FILTER PART NUMBERS:

Refer to engine manufacturers manual for recommendations regarding frequency of service required for engine oil changes and air filter maintenance.

Protect your engine investment, use only original equipment filters.

Model ZTR 5022:	22HP	Pre-Cleaner Foam Element	45083-01
		Cartridge Air Cleaner	45083-02
		Engine Oil Filter	12050-01

TROUBLESHOOTING

MOWER CUT QUALITY:

There are many variables that can affect the cut quality of any riding mower. Type and conditions of grass, cut height setting, engine RPM and ground speed are some of the variables that interact creating differences in cut quality. Examination of one or more of the above will generally produce a quality cut.

The Troubleshooting Chart suggests practices and adjustments that may be helpful in improving cut quality. Your Dixon ZTR dealer is also available to provide assistance to you.

<u>SITUATION</u>	<u>CAUSES</u>	<u>REMEDY</u>
Poor cut quality	Ground speed	Reduce mowing speed
Poor cut quality	Incorrect engine to mower deck belt	Refer to page 38 for part numbers
Poor cut quality	Engine RPM too low	Increase engine RPM to maximum
Poor cut quality	Dull or bent blade	Sharpen or replace as required
Poor cut quality	Un-level mower deck	Refer to page 29 for deck leveling procedure
Poor cut quality	Grass buildup under mower deck	Clean out underside of mower deck
Poor cut quality	Improper blades	Refer to page 38 for part numbers.
Poor cut quality	Uneven tire pressures	Refer to page 37 for correct tire pressures.

TROUBLESHOOTING

DRIVE SYSTEM:

<u>SITUATION</u>	<u>CAUSES</u>	<u>REMEDY</u>
Mower pulls to one side or the other	Forward travel speed adjustment	Refer to page 33 for procedure or consult your dealer for repair
Drive system will not function on either side after changing hydrostatic transmission oil and filter	Incorrect oil filter installed on system Hydrostatic transmissions are "air locked", low or no oil return to tank	Replace with correct Dixon filter Consult your dealer for repairs Continued attempted operation may result in damage to the system
Drive system functions on one side only	Loss of set screw tension on hydrostatic transmission pulley	Consult your dealer for repairs
Loss of power and speed on both hydrostatic transmissions	Incorrect parking brake cable adjustment Incorrect or worn drive belt	Refer to adjustment procedure page 31 or consult your dealer for repair Replace with correct belt
Mower creeps in neutral position	Neutral adjustment	Refer to adjustment procedure page 32 or consult your dealer for repair

TROUBLESHOOTING

ELECTRICAL SYSTEM:

<u>SITUATION</u>	<u>CAUSES</u>	<u>REMEDY</u>
Starter will not turn engine over	Circuit breaker disengaged	Push button to reset Consult your dealer for repair
Starter will not turn engine over	Dead battery	Charge battery
Battery discharge	Poor connections on battery Battery water low Wrong battery installed in mower	Tighten or replace as required
Battery discharge	Engine electrical system not functioning correctly	Have electrical system checked by your dealer
Battery discharge	Engine being operated at too low an RPM	Increase engine RPM Contact your dealer for information

NOTE: Electrical system failures are generally simple in nature, always check the obvious first and then move onto the more complicated parts used. Poor battery service, loose connections, corrosion, frayed or broken wiring, are more likely than component failure.

NOTES



ZTR[®] Mowers



WARNING: The Engine Exhaust from this product contains chemicals known to the State of California to cause cancer, birth defects or other reproductive harm.

©Dixon and ZTR are registered trademarks of Dixon Industries, Inc.

DIXON INDUSTRIES, INC.
A **BLOUNT** International Inc. Co.
PO BOX 1569
COFFEYVILLE KS 67337 0945
3162512000

5000 Series
Part No. 8965
5/98